

 **mitsubishi  
ELECTRIC**  
AIR CONDITIONERS

*Changes for the Better*

# CITY MULTI



## New CITY MULTI YKD-Series

# Further Enhanced Energy Saving

Saving energy is becoming ever more important all around the world. Mitsubishi Electric is at the forefront of this development, with advanced products that realize high-quality energy saving solutions for customers in all fields.

### **Energy saving key point 1** High rated performance

Compared to the conventional series, all models of the new series (8 to 60HP) are improved rated EER/COP. This means less energy will be consumed during peak hours, such as high-temperature periods in the daytime.

### **Energy saving key point 2** High partial-load performance

The new models surpass the conventional series not only in rated specifications but also in terms of partial-load performance. During mornings and evenings, when the temperature is lower and less cooling power is required, better efficiency also enables significant energy savings.

### **Energy saving key point 3** Energy saving assist function

The functions makes it possible to optimize energy saving performance by closely matching the requirements of the installation location. This makes it possible to achieve results that surpass the specifications of the product, contributing to truly energy-saving buildings.



# Advantages of CITY MULTI

## Self-developed Compressor

The compressor is the heart of an air conditioner, contains inverter control. Mitsubishi Electric manages all compressor production processes, from development, design, and manufacture to quality control. We develop high-performance compressors to improve performance to a higher level.

### Compressor designed by Mitsubishi Electric

Key parts of the compressor such as the scroll and motor (core) are designed by Mitsubishi Electric to increase the operation efficiency of the outdoor unit. In order to achieve energy saving operation while also improving reliability, a low-pressure shell compressor is used, resulting in stable long-term running performance.

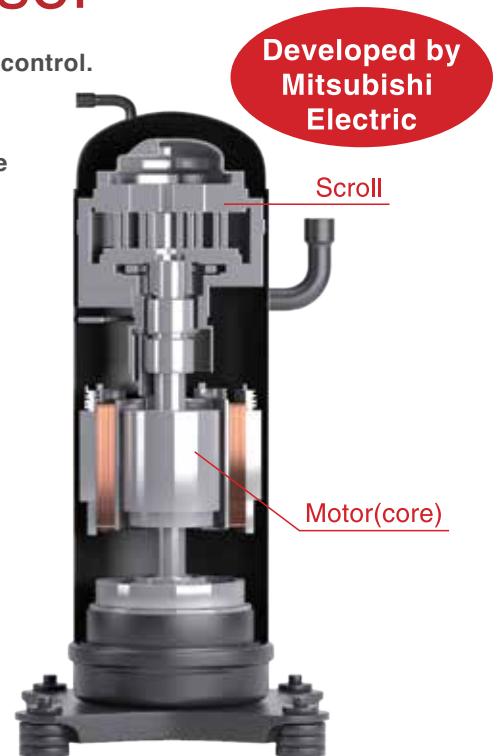

### High reliable low-pressure shells

**High-pressure state**

Discharge

Intake

Compression

Motor

Oil reservoir

**Low-pressure state**

Most of the compressor's area is taken up by low-pressure gas

**Low-pressure shell compressor for top flow models**

Most of the area in the compressor is taken up by the low-pressure gas. The refrigerant is drawn in from the side of the compressor and moves to the bottom of the shell where it flows to the scroll section and is compressed. The compressed high-pressure gas is discharged from the top of the compressor. **This prevents the motor and bearings from being heated up by the compressed high-pressure gas.**

The refrigerant is collected at the bottom of the shell to reduce the rate of compressor damage caused by liquid refrigerant compression.

**Cross section of compressor**

\* except PUMY series

# Energy saving performance

The advantage of CITY MULTI from Mitsubishi Electric is its high energy efficiency, which leads to increased energy savings.

The energy-saving performance of CITY MULTI has been improved to a high level within the industry through technical innovation.

## Smart control for saving energy

The compressor varies its speed to match the indoor cooling or heating demand, thus it only consumes the amount of energy required. When an inverter driven system is operating at partial load, the energy efficiency of the system is significantly higher than that of a standard fixed speed, non inverter system.

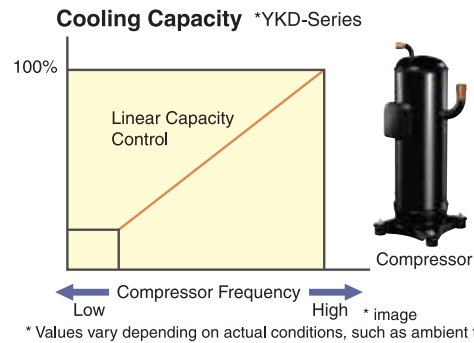

\* Values vary depending on actual conditions, such as ambient temperature.

## The Importance of Partial-Load Efficiency

The energy efficiency ratio (EER) is an index calculated at an ambient temperature of 35°C [95°F]. Actually, the temperature difference between day and night is large, even on hot days. Therefore, it is important to save energy across various temperatures where the EER cannot be measured perfectly. **CITY MULTI can achieve true energy savings by improving efficiency not only under rated conditions, but also under partial-load conditions.**

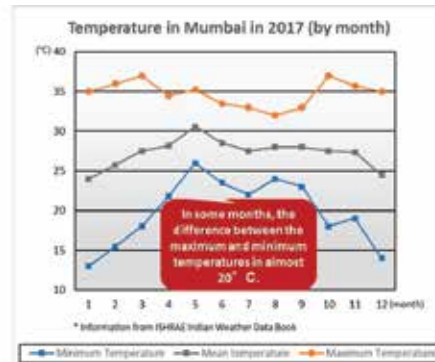
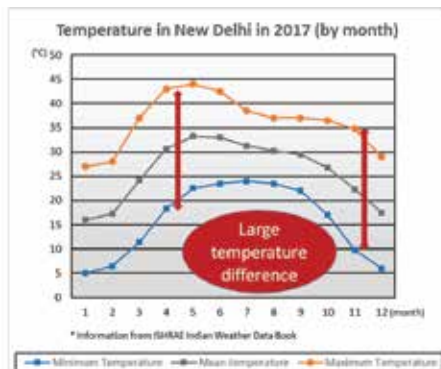
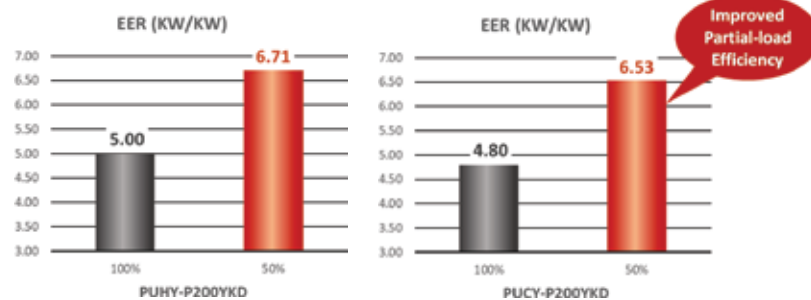

## Energy-saving performance can be further improved by high energy efficiency models.

We offer a range of high-efficiency models in addition to standard models. The energy efficiency Ratio (EER) has improved drastically compared to models produced 20 years ago.

### Comparison of EER (Energy Efficiency Ratio) – 20 HP system

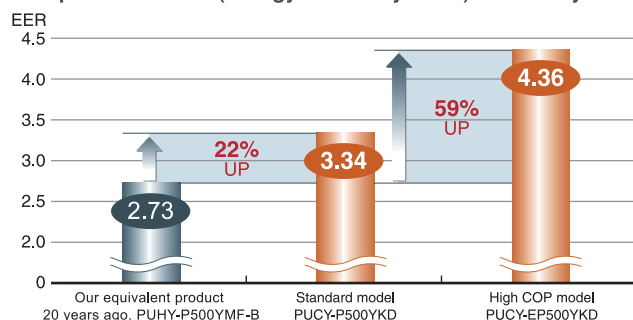

# Advantages of CITY MULTI

## Further enhanced energy savings

### Energy saving assist function

In addition to the basic energy saving design, energy saving assist functions can be activated easily via DIP switch settings. This allows matching the equipment to various installation patterns.

### Evaporating temperature control PUCY P PUCY EP PUHY P PUHY EP

During cooling operation, the temperature of the refrigerant can be controlled according to the air conditioning load. This helps energy efficient operation.

#### ■ Normal mode

The evaporating temperature is kept constant regardless of the load. Even at low loads, the normal evaporating temperature does not change, which leads to energy waste during partial load operation.

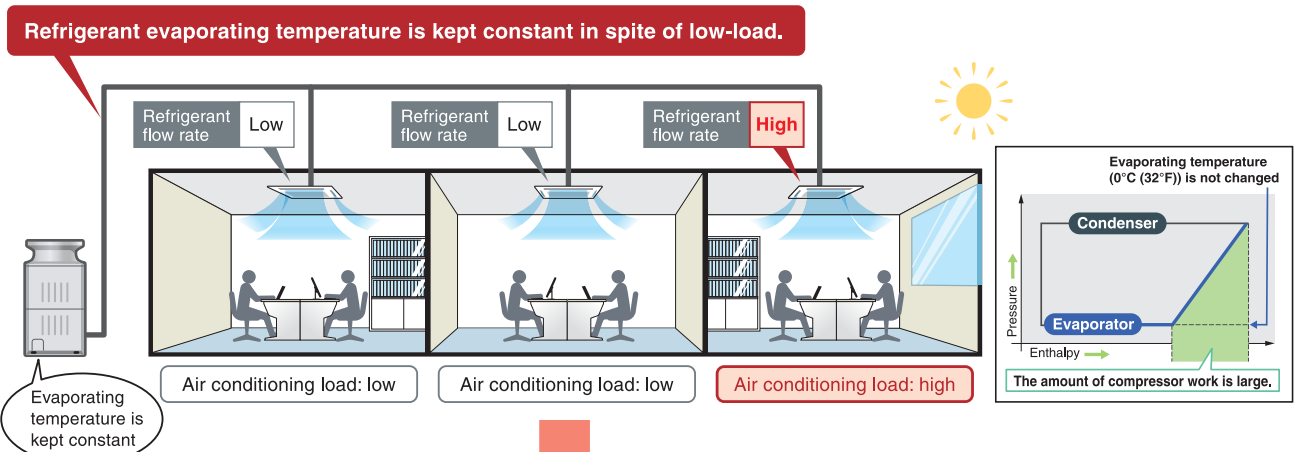

#### ■ Smart evaporation temperature control mode

The YKD series supports evaporating temperature control which adjusts the refrigerant evaporating temperature. Two control methods are available: fixed control and automatic shift control.

\* Changing the evaporating temperature is achieved by changing DIP switch settings on the outdoor unit. Refer to "Evaporating temperature setting method" and the Service Handbook for details.  
 \* Raising the evaporating temperature will lower the latent heat processing capability. Select the appropriate mode for the installation location, taking factors such as ambient temperature into consideration.

#### 1. Fixed control

The target evaporating temperature is changed and controlled to be constant. Selecting an evaporating temperature that is higher than for normal cooling will reduce the load of the compressor and improve operation efficiency.

##### • Concept of evaporating temperature control (fixed control)

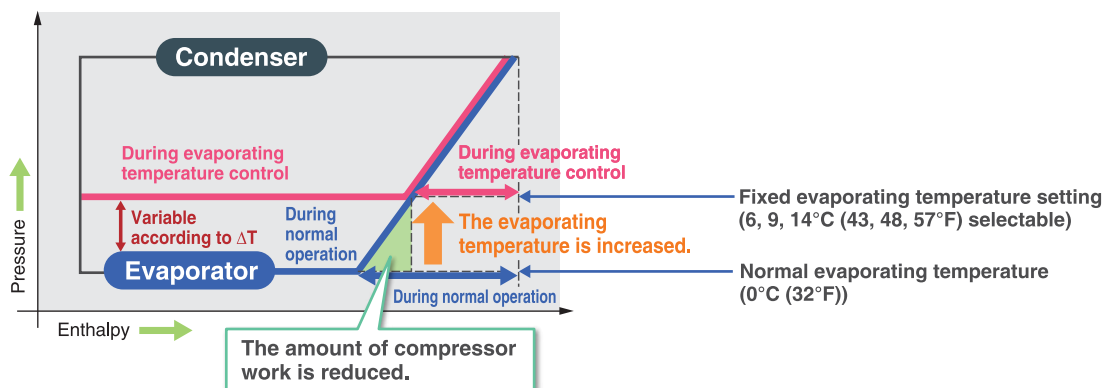

\* Because evaporating temperature will constantly be higher, cooling capacity is reduced, which may result in the room not reaching the set temperature.  
 \* To change the evaporating temperature setting, it is necessary to change the setting of the DIP switch on the outdoor unit.

## 2. Automatic shift control

Evaporating temperature is shifted according to the air conditioning load ( $\Delta T$ ). When approaching the set temperature, evaporating temperature is raised to reduce compressor workload and save energy. Four control patterns can be selected.

### • Concept of evaporating temperature control (automatic shift control)

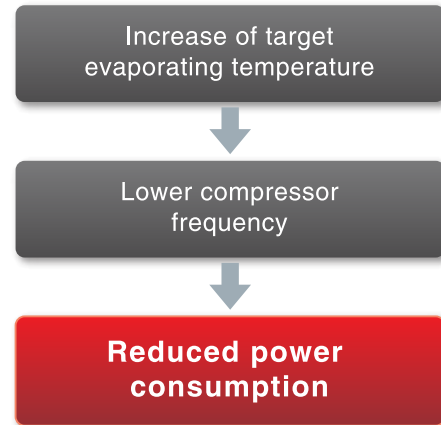
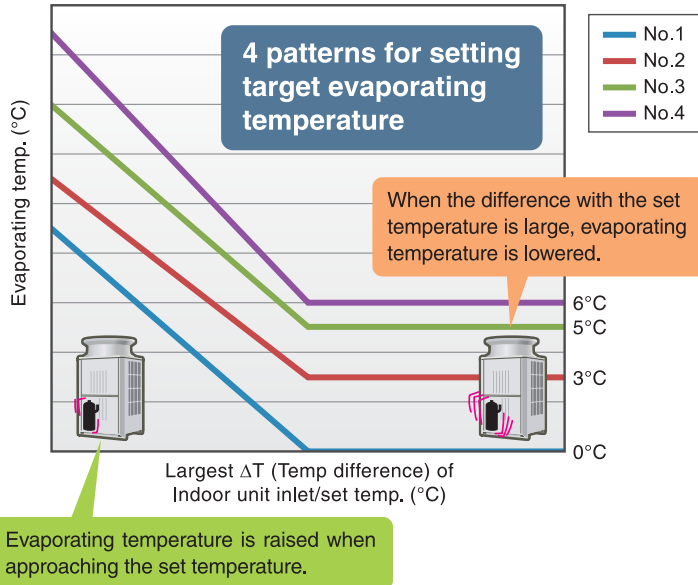

\*1 To activate evaporating temperature control, use terminal external input.  
 \*2 To change the evaporating temperature setting, it is necessary to change the setting of the DIP switch on the outdoor unit.

**High load** At start of operation / With many people inside the room

Outdoor temperature 30°C (86°F)

Room temperature 27°C (80.6°F)

Set temperature 24.5°C (76°F)

Evaporating temperature steady or not changed

**Low load** As room temperature approaches set temperature

Outdoor temperature 30°C (86°F)

Room temperature 25°C (77°F)

Set temperature 24.5°C (76°F)

Evaporating temperature raised

Evaporating temperature is changed according to the difference between room temperature and set temperature.

### Suitable situations

- (1) Locations with mainly sensible heat load by OA equipment (offices and similar)
- (2) Relatively low-load conditions during air conditioning season (mornings or nights)
- (3) When higher temperature of discharge air is desired in windy conditions

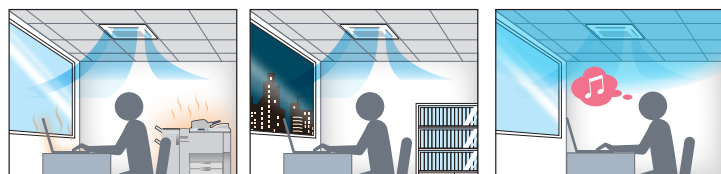

# Advantages of CITY MULTI

## Cooling capacity at high outdoor air temperatures

### 1. Cooling operation possible up to intake temperature of 52°C



In built-up areas with a high density of buildings, winds may be blocked, causing an accumulation of warm air in the vicinity of the outdoor unit. Because the operation range of the YKD series has been guaranteed up to 52°C (125°F), operation will remain stable even in such situations.

#### Example of flow analysis

■ Conditions : Outdoor air temperature = 35°C (DB), Room temperature = 27°C (DB)

#### Built-up area with buildings and outdoor units

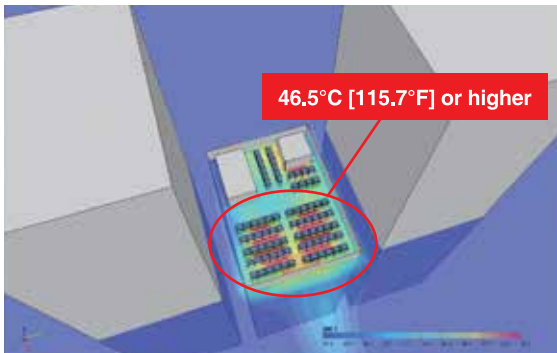

If the passage of air is blocked in a built-up area, the high-temperature air discharged from the outdoor units may be kept around the units.

#### Installation on each floor a high-rise building

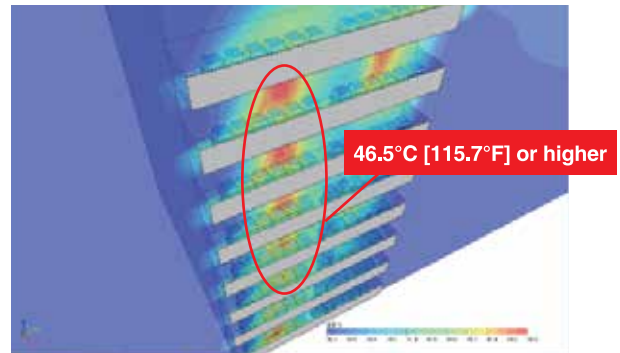

When the outdoor units are installed on balconies, the high-temperature air discharged from the units may be kept in by upper balconies.

Ambient temperature range	
PUHY-P YKD (COOLING)	-5°C [23°F] — 52°C [126°F]
PUHY-P YKD (HEATING)	-20°C [-4°F] — 15.5°C [60°F]
PUCY-P YKD (COOLING)	10°C [50°F] — 52°C [126°F]

#### Suitable situations

Installation in locations such as on balconies or between buildings, where high-temperature air may tend to accumulate.

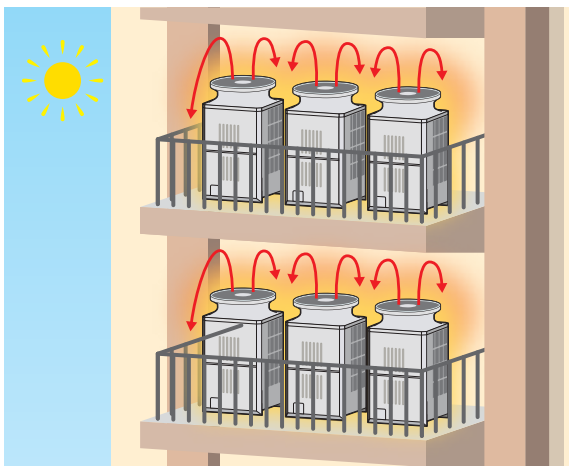

## 2. Cooling operation assist function

### Capacity assist mode

During cooling operation in high outside temperature, cooling capacity tends to be decreased. The new series provides capacity assist mode where the fan speed is automatically raised when the outside temperature reaches or exceeds around 38°C. This prevents a drop in cooling capacity during operation at high outside air temperatures. Comfort is improved, thanks to continued high performance of the unit.

\* Requires a DIP switch setting  
 \* This function will be disabled when the unit is set to the outdoor high static pressure setting or to the night mode setting.  
 The outdoor unit will make more noise due to an increased airflow. Choose the mode according to installation requirements.

Cooling capacity at 100% indoor units running

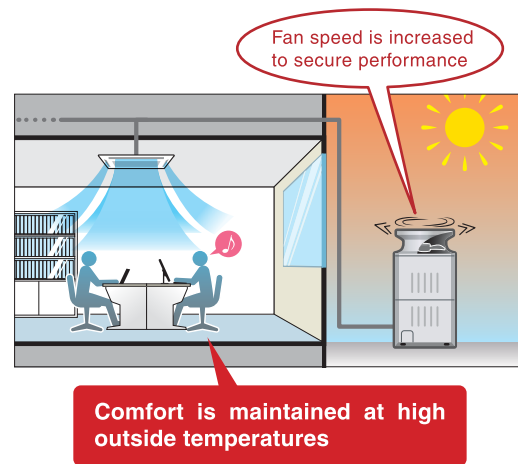
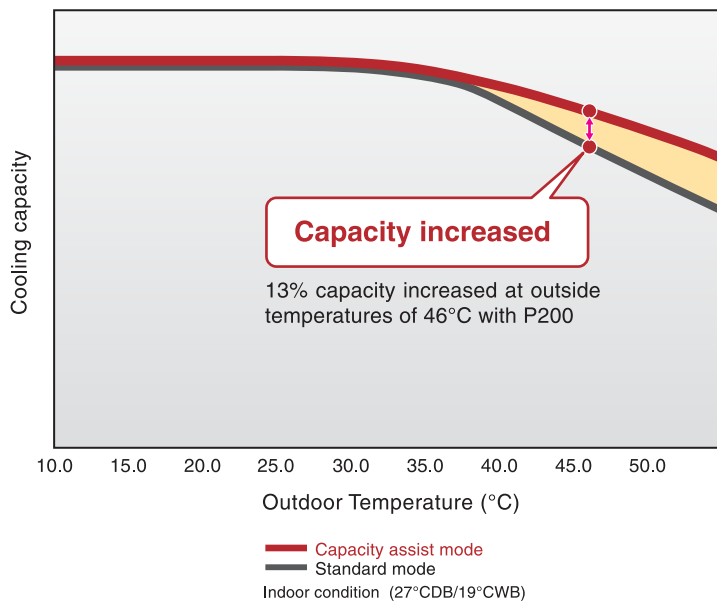

### Rapid mode during startup (Quick-start up)

The rotation speed of the compressor can be raised during the first 30 minutes after cooling startup, to quickly establish comfortable conditions when returning home or at the start of a workday. Restarting after a power outage will also be faster, to quickly cool down the room.

\* Requires a DIP switch setting  
 \* Selecting this mode may increase operation noise. Choose the mode according to installation requirements.

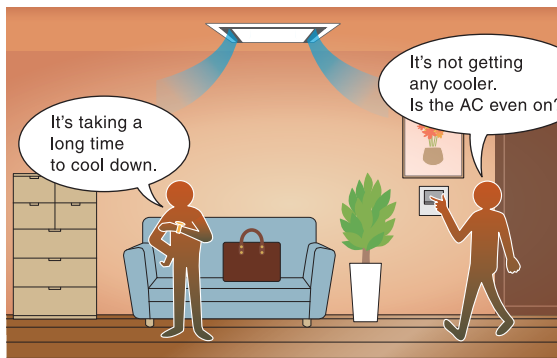

The room does not cool off very quickly, and it takes a while before the room becomes comfortable.

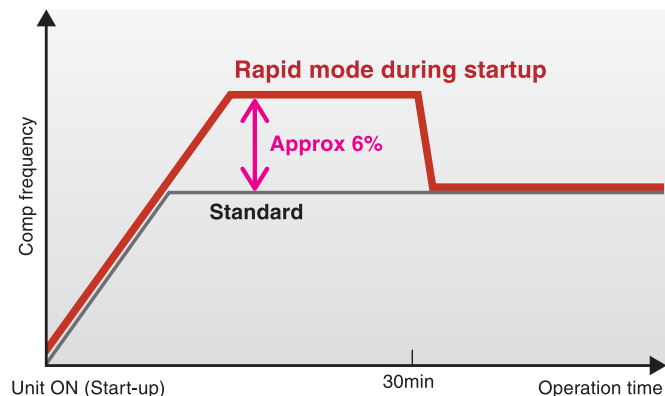

# Advantages of CITY MULTI

## Key Technologies

All major parts of YKD series products reflect technological excellence of Mitsubishi Electric. This results in high energy efficiency, enhanced cooling capacity at high outside air temperatures, and further improved reliability.

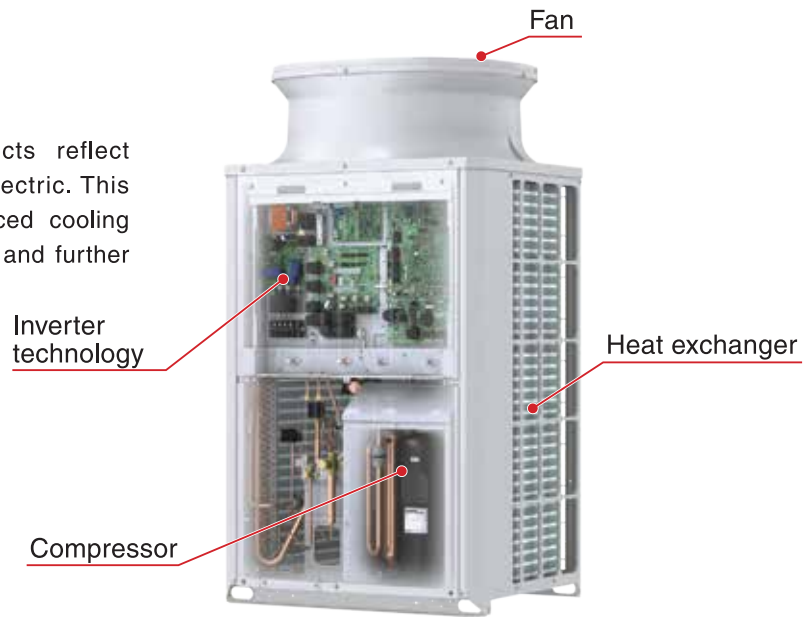

## Inverter technology

As a manufacturer of general electric equipment, our inverter-related components are developed and manufactured using Mitsubishi Electric technology.

All compressors are inverter-driven type and developed and manufactured by Mitsubishi Electric



The compressor varies its speed to match the indoor cooling or heating demand, thus it only consumes the energy amount of energy required.

When an inverter driven system is operating at partial load, the energy efficiency of the system is significantly higher than that of a standard fixed speed, non inverter system. The fixed speed system can only operate at 100%, although full load condition is not prevailed all time. Therefore, fixed speed systems cannot match the annual efficiency of inverter driven systems.

Developed by Mitsubishi Electric

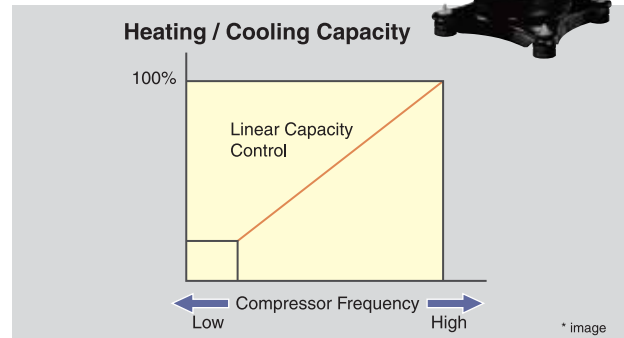

\* Values vary depending on actual conditions, such as ambient temperature.

Intelligent Power Module (IPM) manufactured by Mitsubishi Electric



\*Except PUHY-P200/250YKD and PUHY-EP400/450YKD models.

Power modules manufactured by Mitsubishi Electric are installed in the compressor, which is the core component, as well as in the inverter circuit board that drives the fan. Furthermore, a specialized drive circuit that ensures excellent performance make a high-quality, high-performance inverter possible.

**IPM technology ensures effective operation even at lower partial load and realizes automatic control to operate the air conditioners appropriately according to the situation, resulting in energy savings.**

Developed by Mitsubishi Electric

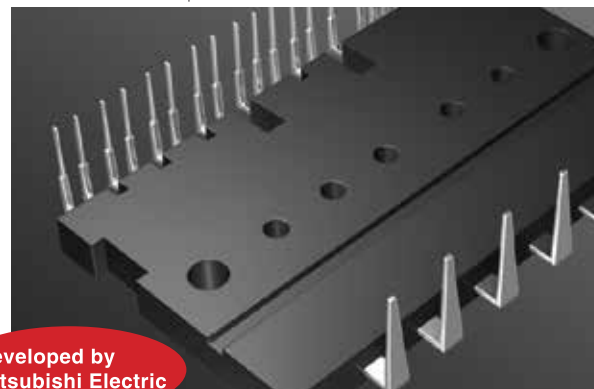

# Compressor

## Multi-valve mechanism

In addition to the conventional discharge port, the new series features two sub-ports, which performs according to the air conditioning load. This prevents excessive compression and improves operation efficiency.

### Conventional structure

		Operation pattern	
		Partial load	Rating, high pressure difference
Main port	Valve 1	Open	Open

### New structure with multi-valve design

		Operation pattern	
		Partial load	Rating, high pressure difference
Main port	Valve 1	Open	Open
Sub-port	Valve 2/3	Open	Closed

The sub-port is opened during partial load operation to discharge the over-compressed gas.

### In case of partial load operation

#### Conventional structure

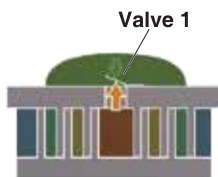
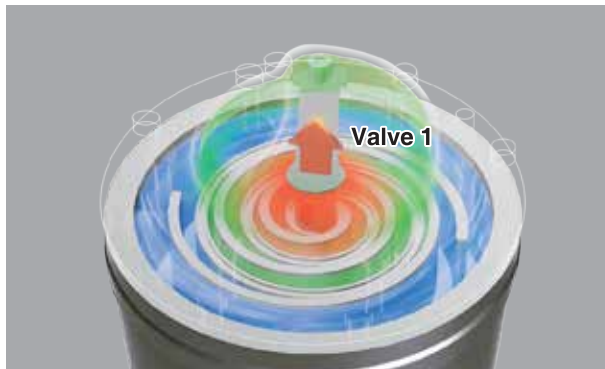

#### New structure with multi-valve design

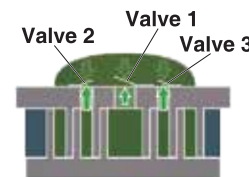
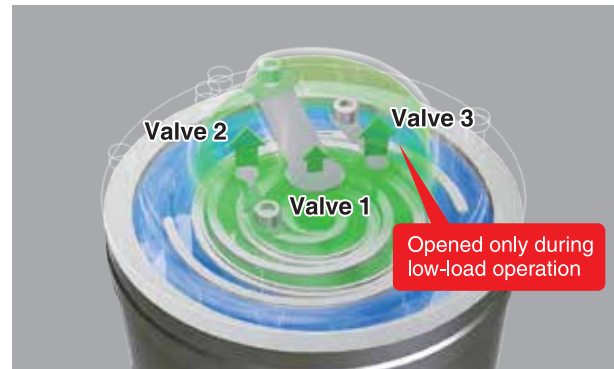

Opened only during low-load operation

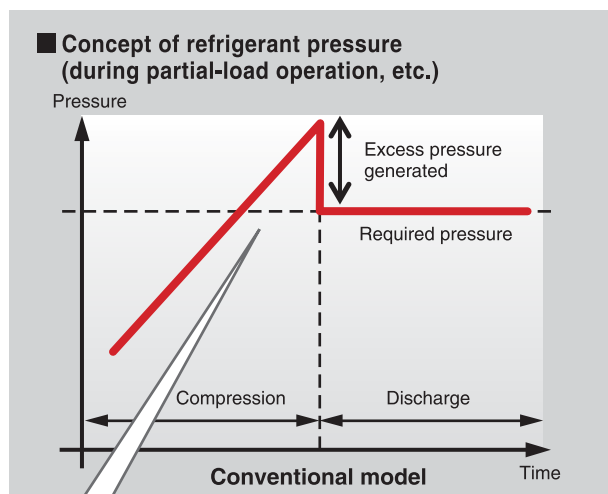

**Conventional model**  
Because there is only one discharge port, compression capacity is first raised regardless of load, and then lowered to the target discharge pressure. This results in operation loss due to over-compression.

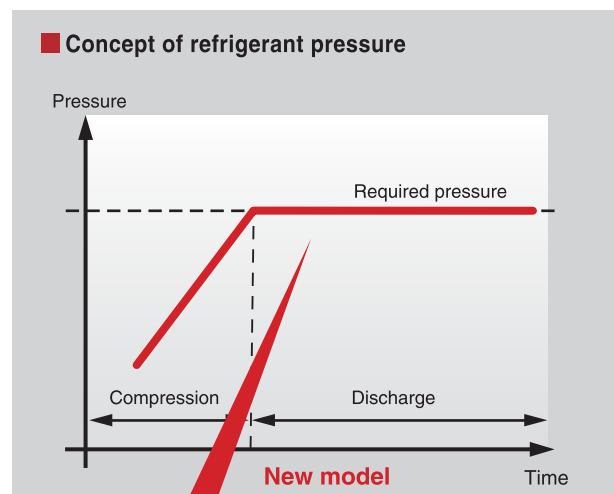

**Multi-valve**  
When the target discharge pressure is reached, the multi-valves are opened to release refrigerant gas. This reduces operation loss due to over-compression.

# Advantages of CITY MULTI

## Compressor

### Snap-in core

Mitsubishi Electric has incorporated a new and original production process that wraps a conductor directly around the split core to create a compact and highly efficient motor.



**Feature 1: Coils wound around each core**

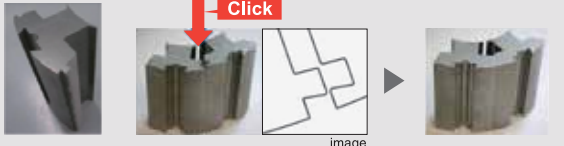

**Feature 2: Snap-in core**

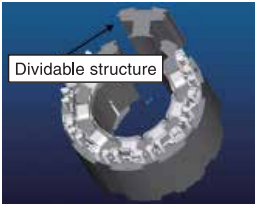

**Compressor motor**

Snap-in core      Cross section Density: high

Motor efficiency is high at low speeds when coil occupancy is high, thus improving compression efficiency for low-load operation.

### Improved high-efficiency motor \*Except for PUC(H)Y P200-350/550/600 Y(S)KD and PUC(H)Y EP400-1050YSKD model.

Whereas the motor core of the conventional model had dead space between the insulator and insulation film, the new model has a smaller insulator with film on the inside. Consequently, the area for copper wire winding has increased by 9%. The wire diameter also was increased by two sizes, resulting in lower resistance and reduced insulation distance. This boosts motor efficiency, thus also improving compressor efficiency.

**Conventional model (YKA)**

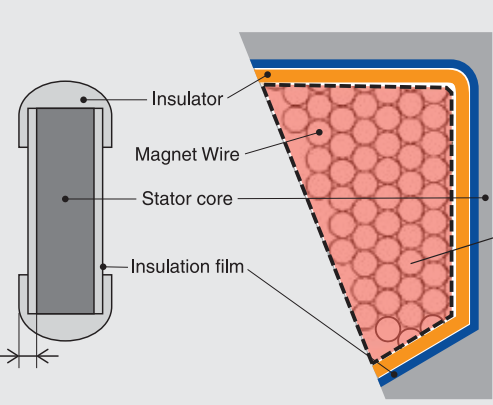

Insulator  
Magnet Wire  
Stator core  
Insulation film

The insulator section is large, and the area where the copper wire can be wound is small.

Increase in area available for winding

**New model (YKD)**

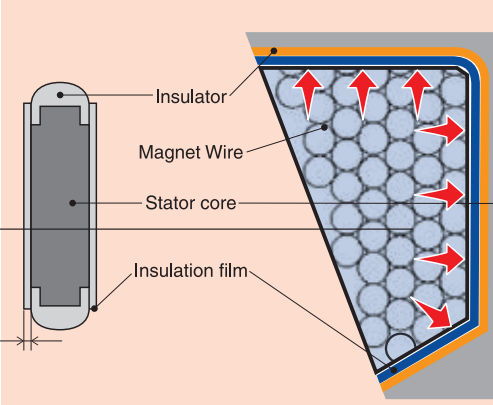

Insulator  
Magnet Wire  
Stator core  
Insulation film

Former insulator section now enables the use of larger gauge copper wire.

## IH (induction heating) warmer

In order to prevent refrigerant and oil from mixing while the air conditioner is stopped, it is necessary to always warm the compressor. Mitsubishi Electric provides the required heating by energizing the windings of the compressor (using a voltage that does not drive the compressor motor) instead of a belt type heater that applies heat from the outside, resulting in reduced loss and lower power consumption. In addition, remains on for 30 minutes after operation is stopped, and subsequently is switched on and off every 30 minutes. Standby power consumption therefore is lower than with a belt heater that is constantly powered.

\* Normally, the compressor is heated while the outdoor unit is stopped to prevent liquid refrigerant from remaining in the compressor and to evaporate the liquid refrigerant in the compressor.

IH warmer  
(without crankcase heater)



**Operation during air conditioner stop**

On/off is repeated every 30 minutes



Crankcase heater not required

Standby power consumption can be reduced when the air conditioner is stopped overnight in offices or other locations.

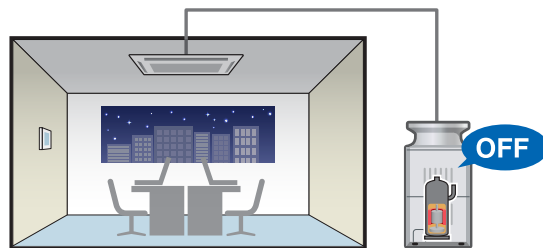

Internal heating reduces power consumption during standby. This provides an advantage over designs that are constantly powered.

## Fan

### Bell-mouth shape design realizes higher air discharge efficiency

This design reduces the fan input value and contributes to energy savings. In addition, more efficient air discharge improves stability during operation at high outside air temperatures.

Conventional model(YHA)

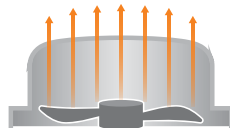

YKD

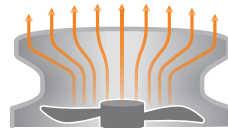

Air is expelled with higher efficiency by temporarily accumulating at the bottom of the bell-mouth shape.

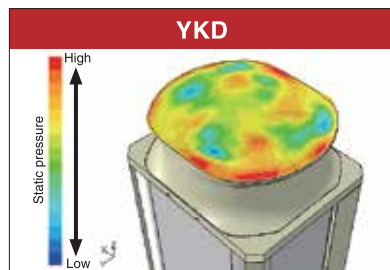
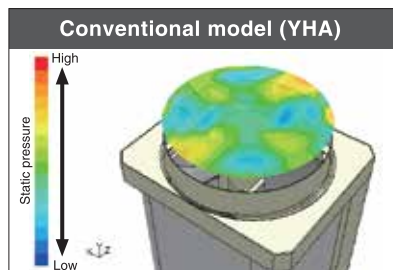

Changes to the bell-mouth shape improve the static pressure during air discharge, resulting in energy saving operation

## Heat exchanger

Grooves are formed in the copper pipe to improve the heat exchange performance.

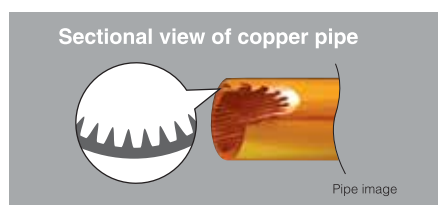

The grooved structure in the copper pipe of the heat exchanger increases the heat exchange area to contact with refrigerant.

# Advantages of CITY MULTI

## High reliability

### 1. Compressor

Liquid and gas refrigerants are separated beforehand by the accumulator to prevent liquid refrigerant from flowing into the compressor. Moreover, compressor structure is filled with low-pressure gas refrigerant. If liquid backflow occurs, the liquid will not enter the scroll of the compressed part directly.

Low-pressure shells    

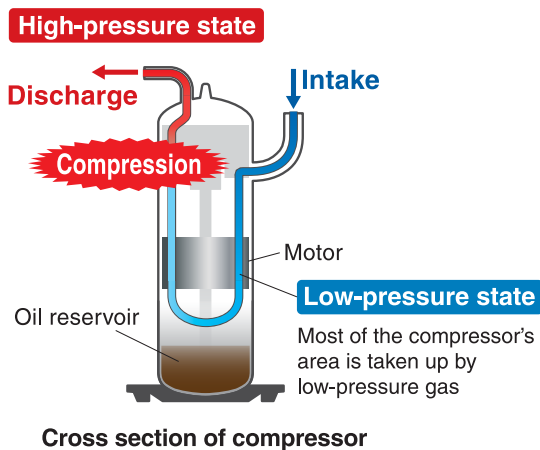

Most of the area in the compressor is taken up by the low-pressure gas. This prevents the motor and bearings from being heated up by the compressed high-pressure gas. The refrigerant is collected at the bottom of the shell to reduce the rate of compressor damage caused by liquid refrigerant compression.

When liquid backflow has occurred

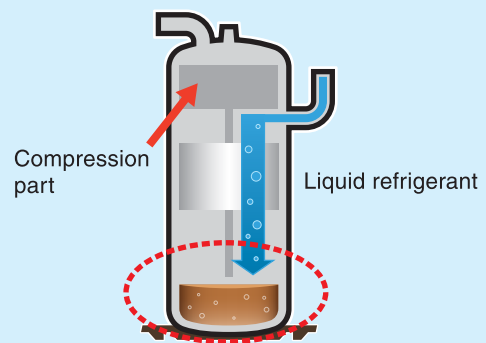

Liquid refrigerant goes to bottom part firstly

Liquid refrigerant doesn't go to compression part directly so that compressor itself is protected from malfunction due to liquid back.

Accumulator for preventing liquid backflow    

When the refrigerant is not completely evaporated by the evaporator, it may remain as a liquid, flowing back into the compressor and causing liquid compression, which poses the risk of serious damage to the compressor. To counter this problem, Mitsubishi Electric uses an accumulator placed between the evaporator and the compressor to separate the liquid refrigerant.

\* Adding too much refrigerant will cause excess refrigerant to accumulate in the accumulator, resulting in liquid back flow. Be sure to add only the proper amount of refrigerant.

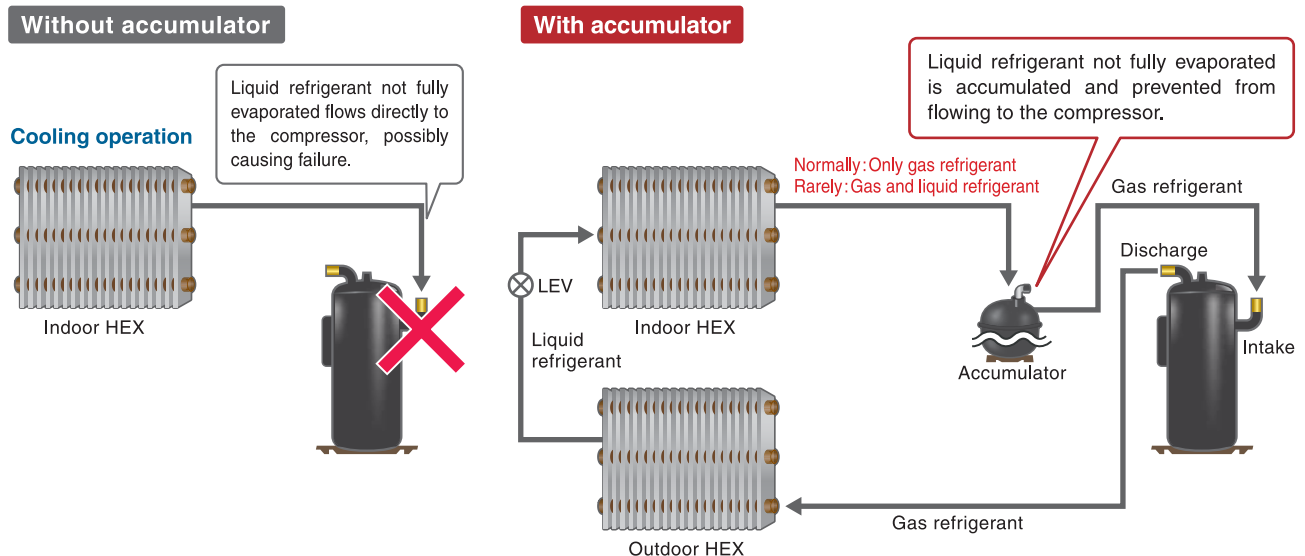

## Operation with one compressor up to 20HP. PUCY P PUCY EP PUHY P PUHY EP

Outdoor units can be operated by one compressor, which contributes to improve service with less refrigerant piping work and components.

### 1 compressor model



S module



Lower number of required key parts reduces maintenance requirements

No need for our model

XL module

## Rotation control PUCY P PUCY EP PUHY P PUHY EP

With the combination model, the outdoor units operate alternately. This reduces the operating load and leads to a longer service life.

After operation for 2 hours or more, the next operation will be started from the outdoor unit "2." The unit to be started first is changed to equalize the operating time of the units.

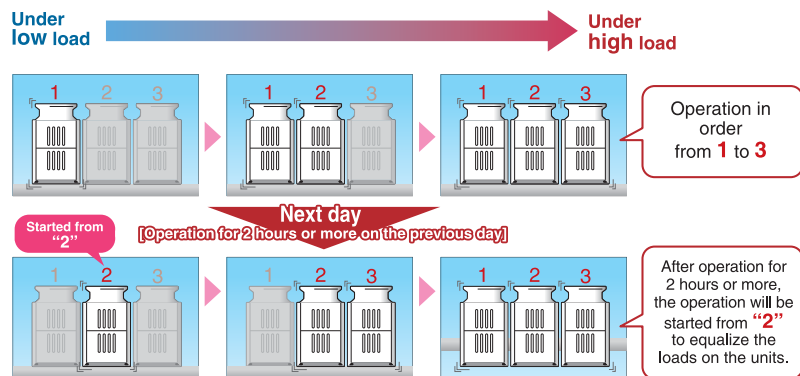

## Emergency operation mode PUCY P PUCY EP PUHY P PUHY EP

Emergency operation is possible with the indoor unit's remote control. With the combination model, if one outdoor unit is malfunctioning, the other outdoor unit temporarily performs emergency operation.

### With emergency operation function

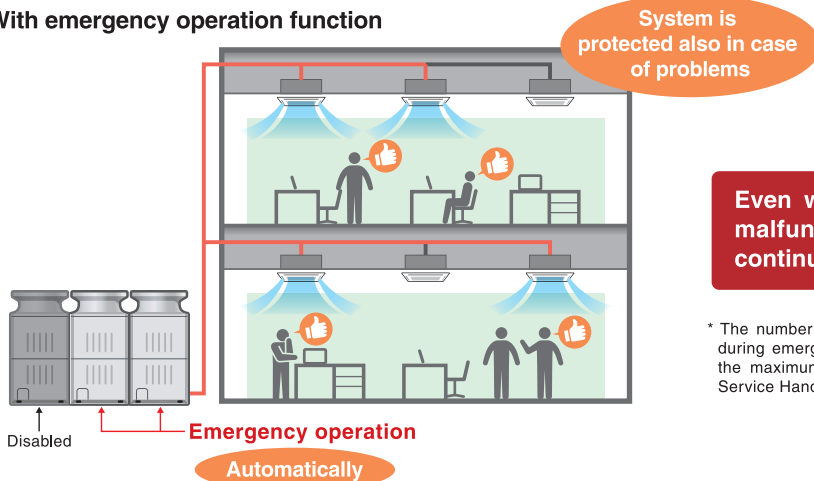

\* The number of indoor units that can continue to operate during emergency operation is limited. For information on the maximum total capacity of indoor units, refer to the Service Handbook for the outdoor unit.

# Advantages of CITY MULTI

## High reliability

### 2. Electric parts

#### Allowable operating up to $\pm 10\%$ voltage range



Operation of this model is guaranteed even for voltages up to 10% more or less than the indicated allowable voltage.

Reliable operation with support for voltage range of up to  $\pm 10\%$

Power source  
3N~  
50/60Hz, 380/400/415V



#### Naturally cooled PCB (Print circuit board)



PCBs (printed circuit boards) carry a large number of electronic components. When operation load increases, suitable cooling measures are required.

Mitsubishi Electric places PCBs in the natural air flow path which enables air cooling to maintain efficiency and improve reliability of each electronic component.

PCB is naturally cooled by air

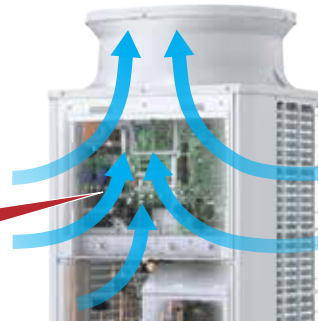

#### Access from front panel



Electrical parts are concentrated in the upper part of the panel which can be opened for easy replacement of PCBs if required.

Because the compressor is located in the lower right when the panel is opened, the service technician can easily perform maintenance from the front.

Easy to access

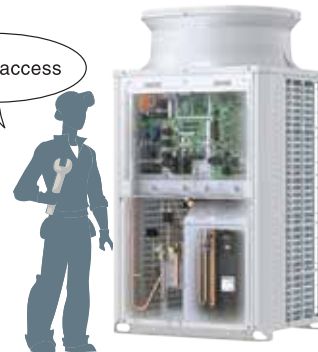

#### Phase reversal protection



When the phase sequence of a three-phase system is incorrect, the motor runs in the opposite direction. In many cases, this can cause a hazardous condition.



### 3. Corrosion resistance

Even in installation environments near coastal areas, Mitsubishi Electric products reduce the effects of corrosion due to salt damage by using a special coating designed for outdoor units.

\* Effectiveness varies depending on the installation location.

#### Film coating on PCB (Print circuit board)

The printed circuit boards are protected by a film coating of polyurethane that covers the entire board to ensure resistance against salt corrosion.

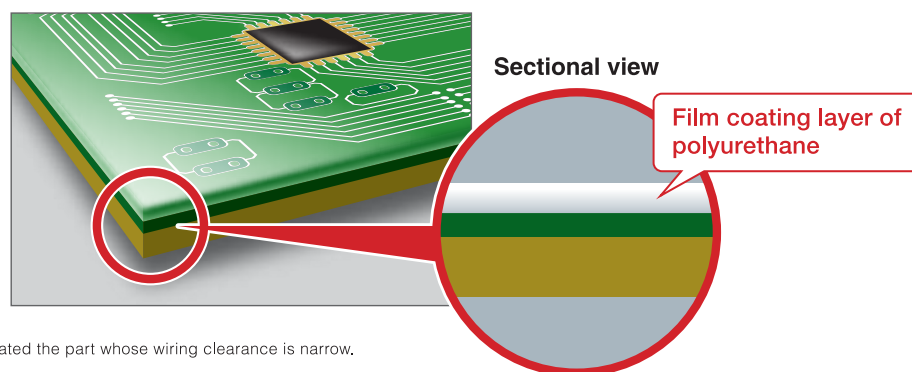

\* Standard model is only coated the part whose wiring clearance is narrow.

#### Polyester coated sheet

To prevent corrosion of the unit even in locations subject to the influence of sea breezes, the outdoor units are made with polyester coated steel sheets compliant with the JRA 9002 standard. The panel coating is used both on standard models and BS models, while BS models also include a thicker coating.

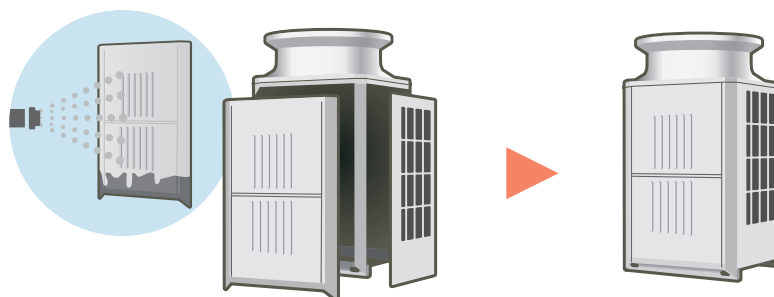

#### Fin treatment on heat exchanger

The anti-corrosion fin treatment on the heat exchanger is especially effective in urban environments where traffic pollutions can damage the aluminum fins, reducing the capacity and life expectancy of the unit. All YKD series feature this Fin treatment.

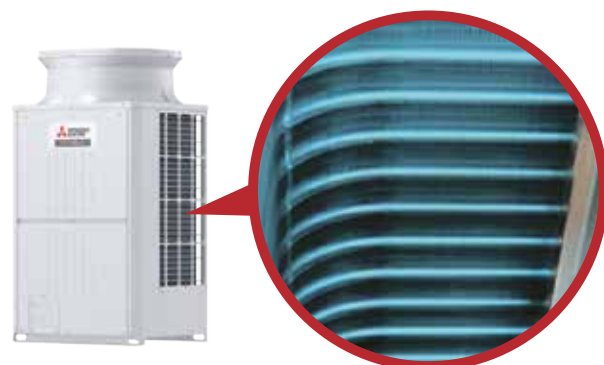

# Advantages of CITY MULTI

## High reliability

### 4. Operation support function

Without requiring any special settings or control steps, Mitsubishi Electric's original M-NET system enables other indoor units to continue operation even when one unit has stopped due to malfunction.

\* Support for PUMY and PQHY models available.

#### With M-NET indoor/outdoor unit communication function (CITY MULTI)

Because Mitsubishi Electric's M-NET transmission line can also supply power, it is possible to close the LEV of indoor units that has caused problem through control command from outdoor unit. This eliminates the risk of condensation and enables the other units to keep working.

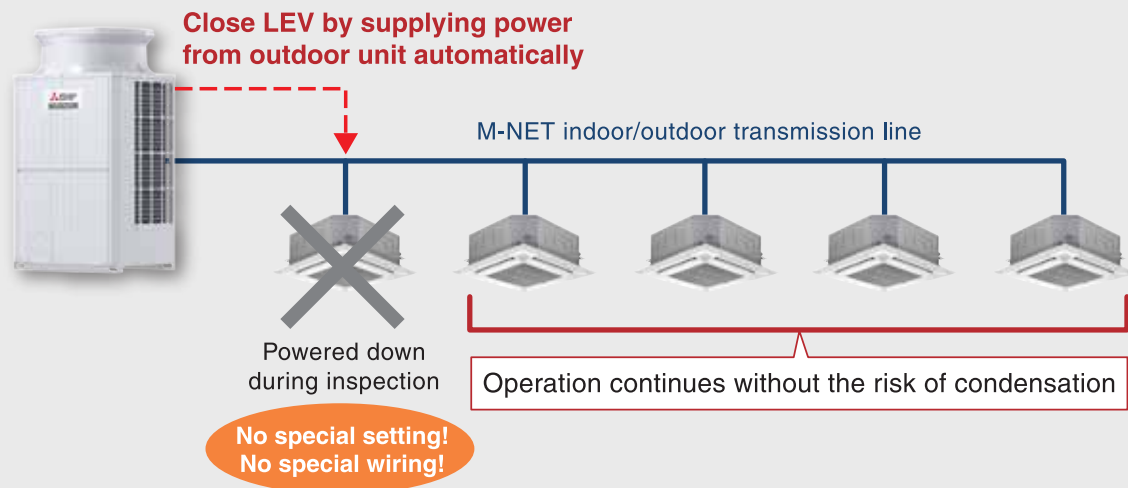

### Flexible maintenance

Even if the system in one guest room cannot be used, air conditioning in other rooms does not need to be shut down, allowing business to continue.

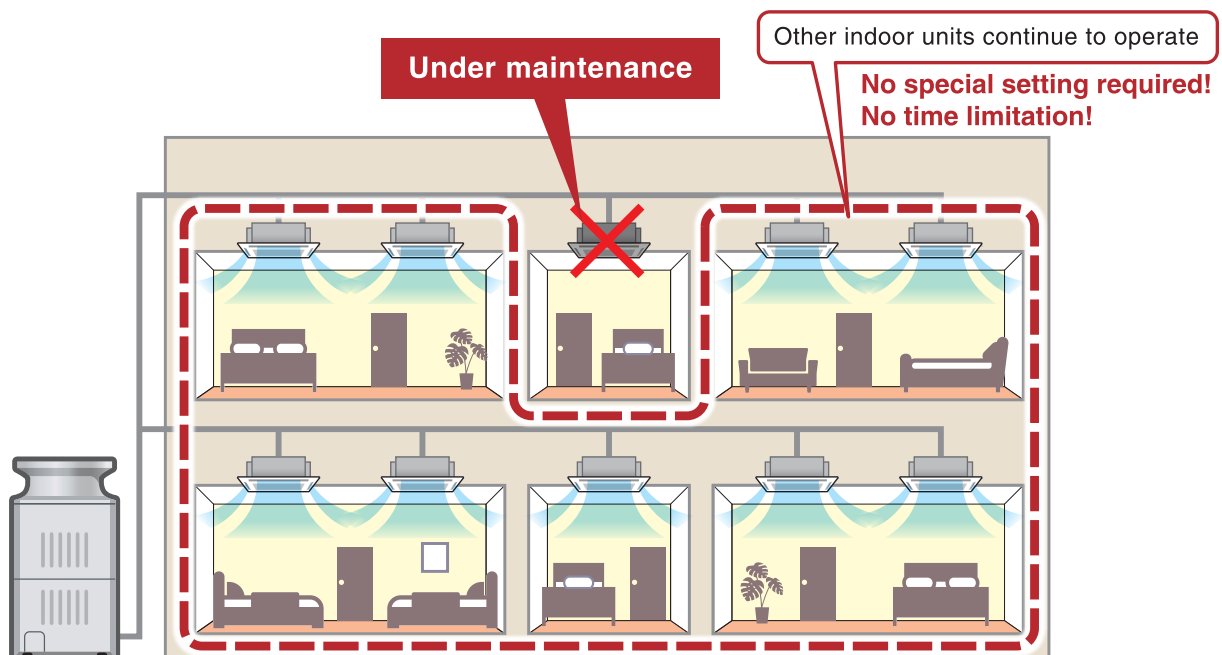

# High installation flexibility

## 1. Flexible wiring design

### Flexible M-NET design

The total wiring length of the original M-NET system connecting the CITY MULTI units of Mitsubishi Electric is unlimited. The system also supports multiple branching levels which greatly increases design flexibility for various buildings.

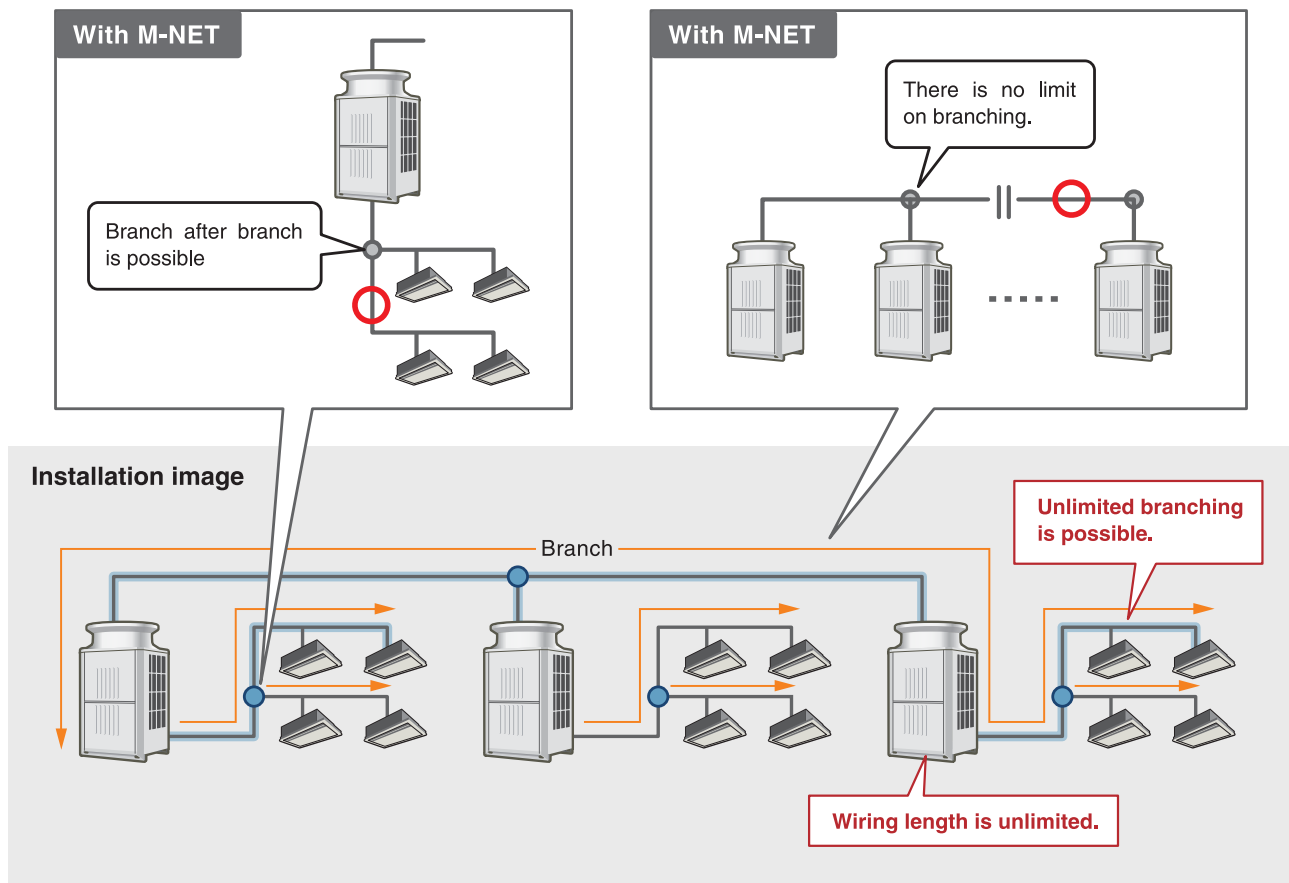

\* Because the maximum power-supply distance of M-NET communication is 200 meters, a booster unit is required over 200 meters. Refer to "Explanatory material for M-NET 1000m" for details.

## 2. Flexible external static pressure setting

### Selectable external static pressure of the outdoor unit

The static pressure specification of the outdoor unit can be selected (0, 30, 60 Pa). This facilitates installation of the unit on each floor of a high-rise building or on balconies.

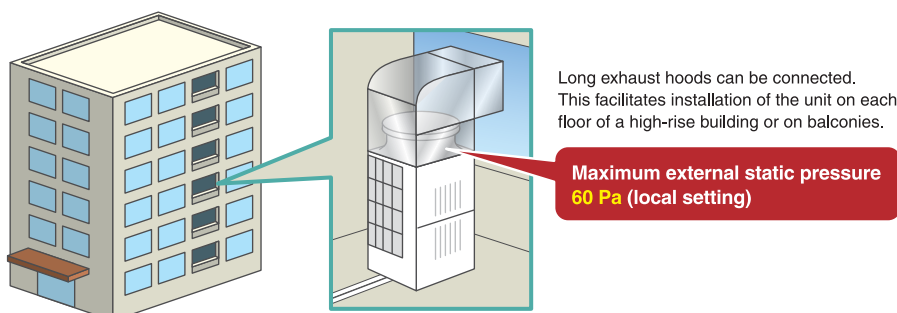

# Advantages of CITY MULTI

## High installation flexibility

### 3. Long piping length

Piping design also provides the flexibility to match the requirements of various buildings. With CITY MULTI, even large-scale building installations are no problem.

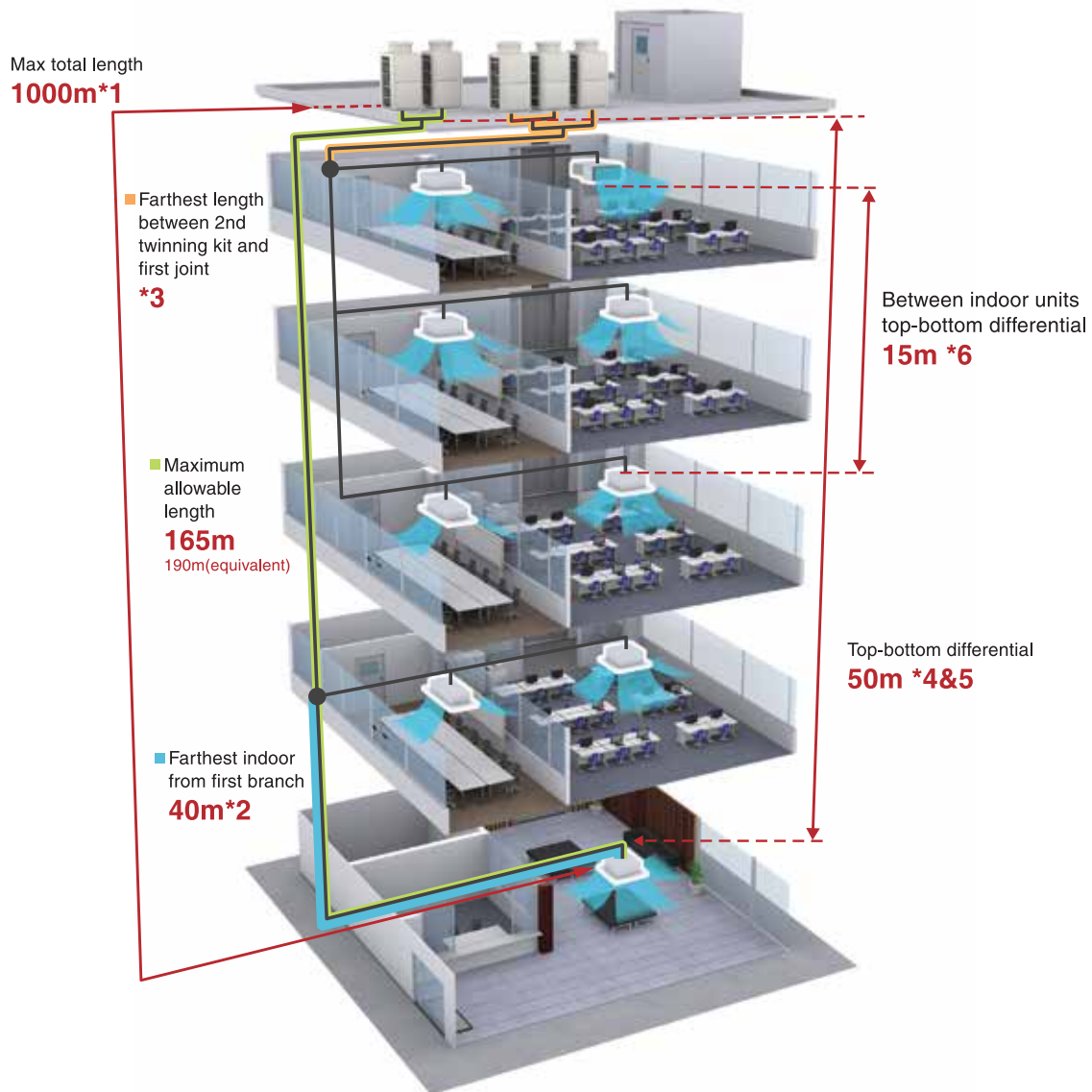

Refrigerant Piping Lengths	Maximum meters [feet]
Total length .....	1,000 [3,280]*1
Maximum allowable length .....	165 (190 equivalent) [541 (623)]
Farthest indoor from first branch .....	40 [131]*2
Farthest length between 2nd twinning kit and first joint .....	*3
Vertical differentials between units	Maximum meters [feet]
Indoor/outdoor (outdoor higher) .....	50 [164]*4
Indoor/outdoor (outdoor lower) .....	40 [131]*5
Indoor/indoor .....	15 [49]*6

\*1 The maximum total piping length in systems with model units P1400 through P1500 800 m [2625 ft.].

\*2 90m is available. When the piping length exceeds 40m, use one size larger liquid pipe starting with the section of piping where 40m is exceeded and all piping after that point.

[for PUCY-P-YKD(-BS) / PUCY-EP-YKD(-BS)]

\*3 In systems with model units P1400 through P1500, pipe length restrictions apply to the main pipes as follows:  
P1400: 110 m [360 ft.] max.  
P1450: 90 m [295 ft.] max.  
P1500: 60 m [197 ft.] max.

\*4 Depending on the model and installation conditions, top-bottom differential 90m [295ft]. For more detailed information, please contact your nearest sales office or distributor.

\*5 4 m [13 ft.] or less in cooling at outdoor temperature 10°C [50°F] or lower for heat pump series.

\*6 30m is available. If the height difference between indoor units exceeds 15m [49 ft.] (but does not exceed 30 m [98 ft.]), use pipes that are one size larger for indoor unit liquid pipes.

[for PUCY-P-YKD(-BS) / PUCY-EP-YKD(-BS) / PUHY-(E)P-YKD(-BS)]

# Other useful information

## Low noise mode (night mode) PUCY P PUCY EP PUHY P PUHY EP

This mode reduces noise by limiting the compressor frequency and the number of rotations made by the outdoor fan. The user can select their preferred level.

\* Cooling/heating capacity drops during low-noise mode operation.  
\* This function can be set by change of dipswitch.



### PUHY-P200YKD

standard 57dB  
↓ 13 dB down  
 Low noise mode **44dB\***

\* Operation noise may increase due to the installation environment or the operation status.

- Increased adaptability and model selection range for buildings where low noise is essential
- Low noise mode can also be selected after delivery using DIP switches

**Changing low noise mode to suit the installation location allows adaptation to the surrounding environment.**

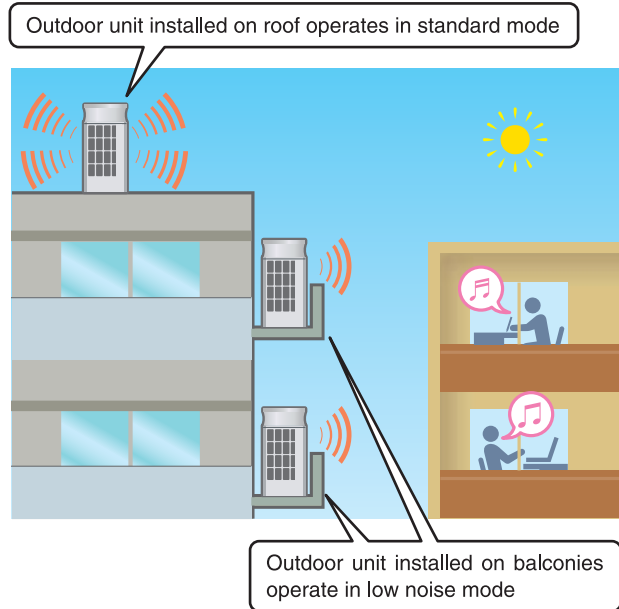

AE-200E

Low noise mode can be scheduled from the Web browser of AE-200E by connecting the PC.

## System changeover (for heat pump) PUHY P PUHY EP

### ■ Normal switching between cooling and heating

With CITY MULTI's switchable cooling/heating models, in order to switch from cooling to heating, the operation mode of all indoor units performing cooling operation needs to be manually switched.

### ■ Using system-changeover to switch between cooling and heating

Depending on the dip switch settings, all indoor units can automatically switch their operation mode according to the operation mode of a specific indoor unit (the unit with the smallest M-NET address). Operation can be automatically switched between cooling and heating according to the temperature difference between the preset temperature on a specific indoor unit and the room temperature.

\* Please avoid the indoor unit with the smallest number address to group with other indoor units.

### Suitable situations

When both cooling and heating operations are required in a single day due to an extreme differences between the hottest and coldest parts of the day.

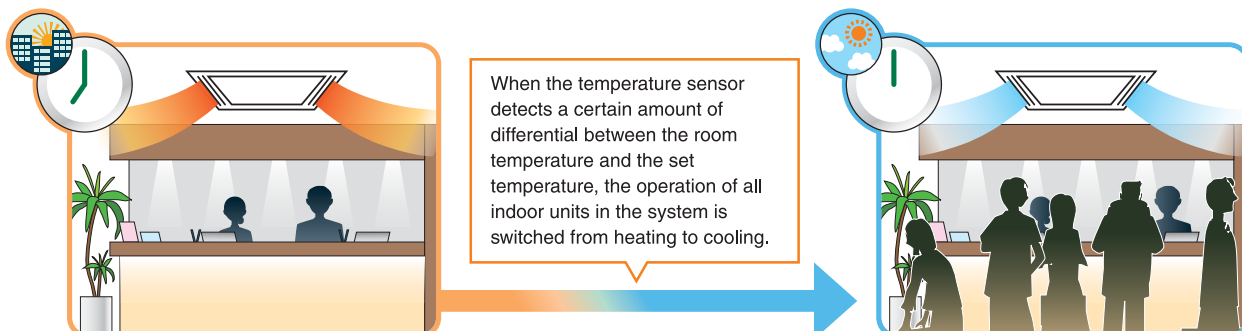

\* The operation of all indoor units connected to the same outdoor unit is switched.

# S-series

## PUMY

The line-up of side-flow type outdoor units includes models from 4 HP to 12 HP, which offers flexibility in installations in tight spaces. This type is suitable for small-scale offices and residences. 1-phase type (VKM) and 3-phase type (YKM/YBM) are available.



### Heat pump

- PUMY-SP VKM
- PUMY-P YKM
- PUMY-P YBM

### Cooling only

- PUMY-CP VKM
- PUMY-CP YKM
- PUMY-CP YBM

### Installation image

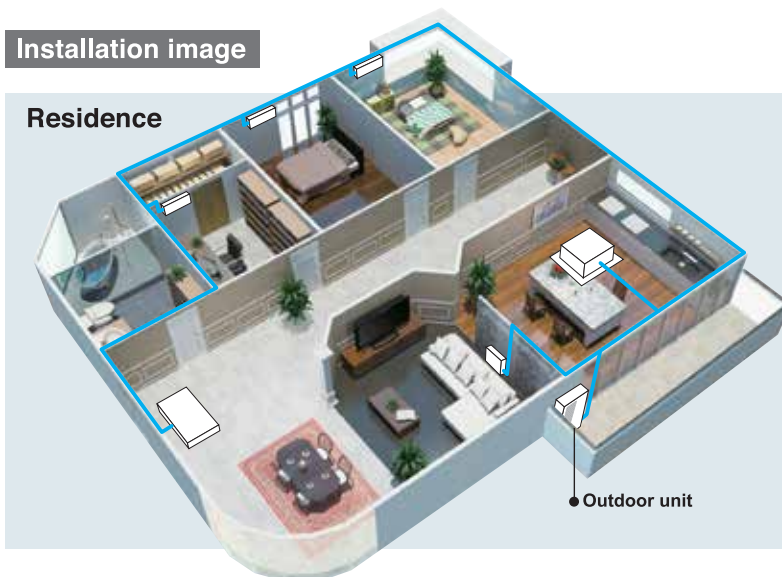

### Advantage of PUMY (for residences)

One outdoor unit (10 HP-12 HP) can be connected up to 29 indoor units (P15-250). Even when indoor units are installed in many rooms, one outdoor unit can connect multiple indoor units.

↓  
**Space savings**

### New released 10-12 HP model features

Expand line-up for cooling only model and Release heat pump (3-phase type) model

Model	100	125	140	175	200	225	250	300
Heat pump	SP100-140VKM			P175-225YKM			P250-300YBM	
Cooling only	CP100-140VKM			CP175-225YKM			CP250-300YBM	

10-12HP (P250-P300) is newly added!

### Heat pump



SP100-140

P175-225

P250-300

### Cooling only



CP100-140

CP175-225

CP250-300

## Piping length

[CP100-140VKM]  
[SP100-140VKM]

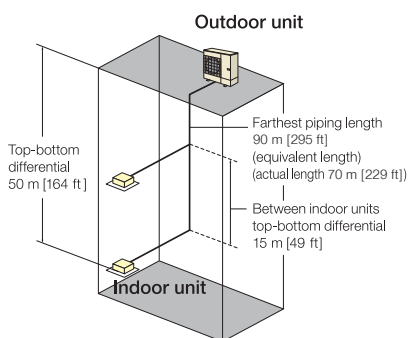

**Refrigerant Piping Lengths**      **Maximum meters [feet]**

Total length	120 [393]
Maximum allowable length	70 (90 equivalent) [229 (295)]
Farthest indoor from first branch	50 [164]*1

**Vertical differentials between units**      **Maximum meters [feet]**

Indoor/outdoor (outdoor higher)	50 [164]
Indoor/outdoor (outdoor lower)	30 [98]
Indoor/indoor	15 [49]

[CP175-225YKM]  
[P175-225YKM]

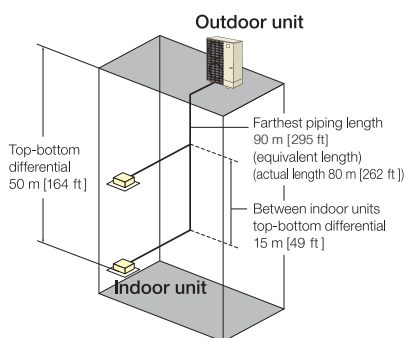

**Refrigerant Piping Lengths**      **Maximum meters [feet]**

Total length	150 [492]
Maximum allowable length	80 (90 equivalent) [262 (295)]
Farthest indoor from first branch	30 [98]

**Vertical differentials between units**      **Maximum meters [feet]**

Indoor/outdoor (outdoor higher)	50 [164]
Indoor/outdoor (outdoor lower)	40 [131]
Indoor/indoor	15 [49]

[CP250-300YBM]  
[P250-300YBM]

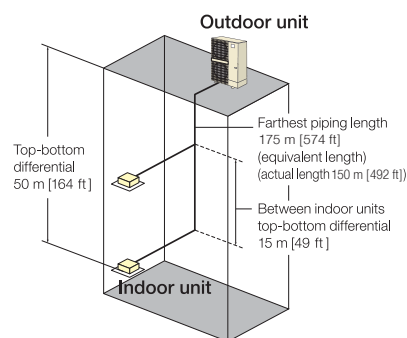

**Refrigerant Piping Lengths**      **Maximum meters [feet]**

Total length	310 [1,017]
Maximum allowable length	150 (175 equivalent) [492 (574)]
Farthest indoor from first branch	30 [98]

**Vertical differentials between units**      **Maximum meters [feet]**

Indoor/outdoor (outdoor higher)	50 [164]
Indoor/outdoor (outdoor lower)	40 [131]
Indoor/indoor	15 [49]

\*1 Use liquid pipe of ø9.52 for less than P50 indoor units, when farthest length from the first branch exceeds 30m.

## Wide range of available according to use pattern

① Operation guaranteed at an outside air temperature of up to 52°C [125°F].

- New inverter technology has made it possible for units to operate at an outdoor air temperature as high as 52°C [125°F].
- Performs well even in narrow spaces and in multiple installations where heated air stagnates.

■ Operation at high temperatures (52°C/125°F)

Operating range (cooling operation)

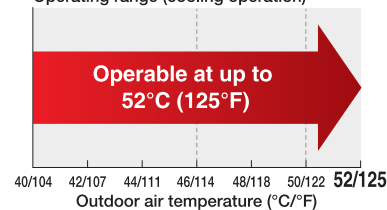

## Cooling operation at 52°C and rated capacity at 43°C

\*Only for PUMY-CP VKM & PUMY-SP VKM





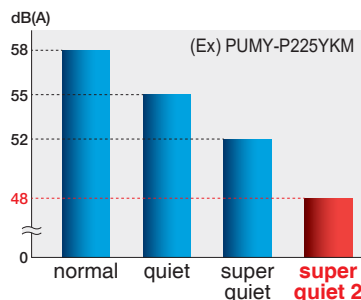

② Super silent mode

All models have two super quiet modes in addition two general quiet modes, and a suitable noise mode can be selected from among the four available modes. The noise level can be set according to the application, for example, in a residential zone where noise may be an issue.

- \* Capacity reduction differs by mode setting.
- \* PAC-SC36NA-E is required to activate this mode.
- \* Available during cooling only.



# Wide selection of outdoor units

System	Series	Type	Model name	HP												
				Model	4	5	5.5	7	8	9	10	12	14	16		
				P100	P125	P140	P175	P200	P225	P250	P300	P350	P400			
Air cooled	S	Cooling only	<b>S-Series</b> PUMY-CP VKM (-BS) PUMY-CP YKM (-BS) PUMY-CP YBM (-BS)		VKM			YKM			YBM					
		Heat Pump	<b>S-Series</b> PUMY-SP VKM (-BS) PUMY-P YKM(-BS) PUMY-P YBM(-BS)		VKM			YKM			YBM					
	Y	Cooling only	<b>Y-Series</b> PUCY-P YKD(-BS) PUCY-P YSKD(-BS)		S				8			10	12			
			<b>Y-Series - High Efficiency</b> PUCY-EP YSKD(-BS)		L										14	16
Heat Pump		S	<b>Y-Series</b> PUHY-P YKD(-BS) PUHY-P YSKD(-BS)		S				8			10	12			
			<b>Y-Series - High Efficiency</b> PUHY-EP YSKD(-BS)		L										14	16
	XL															

\*1. Indicates S, L, XL modules

\*2. The circled numbers in the table indicate horse power, and the combination of S, L, and XL modules.



OUTDOOR UNIT

**S-series**

PUMY-CP VKM (-BS)



Model		PUMY-CP100VKM (-BS)	PUMY-CP125VKM (-BS)	PUMY-CP140VKM (-BS)
Power source		1-phase 220-230-240 V, 50 Hz; 1-phase 220 V, 60 Hz		
Cooling capacity (Nominal)	*1 kW	11.2	14.0	15.5
	*1 BTU/h	38,200	47,800	52,900
	Power input kW	2.80	3.84	4.70
	Current input A	12.99-12.42-11.90, 12.99	17.81-17.04-16.33, 17.81	21.80-20.85-19.98, 21.80
EER	kW/kW	4.00	3.65	3.30
Temp. range of cooling	Indoor temp. W.B.	15 to 24°C (59 to 75°F)		
	Outdoor temp. D.B.	10 to 52°C (50 to 126°F)		
Indoor unit connectable	Total capacity	50 to 130% of outdoor unit capacity		
	Model/Quantity	CITY MULTI		
		15-125/7	15-140/10	15-140/12
Sound pressure level (measured in anechoic room)	*2 dB <A>	52/-	53/-	54/-
Refrigerant piping diameter	Liquid pipe mm (in.)	9.52 (3/8)		
	Gas pipe mm (in.)	15.88 (5/8)		
Fan	Type x Quantity	Propeller Fan × 1		
	Air flow rate	m³/min	78.8	
		L/s	1,313	
		cfm	2,782	
*3 Motor output	kW	0.20 x 1		
Compressor	Type x Quantity	Twin rotary hermetic compressor × 1		
	Starting method	Inverter		
	Motor output	kW	2.2	2.7
External finish		Galvanized Steel Sheet Munsell No. 3Y 7.8/1.1		
External dimension H x W x D	mm	981 × 1050 × 330 (+25)		
	in.	38-5/8 × 41-3/8 × 13 (+1)		
Protection devices	High pressure protection	High pressure switch		
	Inverter circuit (COMP./FAN)	Overcurrent detection, Overheat detection (Heat Sink thermistor)		
	Compressor	Compressor thermistor, Overcurrent detection		
	Fan motor	Overheating, Voltage protection		
Refrigerant	Type x original charge	R410A 2.9kg		
Net weight	kg (lbs)	86 (190) *4		
Heat exchanger		Micro Slit Fin and Copper tube		
Defrosting method		-		
Optional parts		Joint: CMY-Y62-G-E		

**Notes:**

\*1 Nominal conditions

	Indoor	Outdoor	Pipe length	Level difference
Cooling	27°C DB/19°C WB (81°F DB/66°F WB)	35°C DB (95°F DB)	7.5m (24-9/16ft.)	0m (0ft.)

\*2 Up to 150% can be connected. However, up to 130% for simultaneous operation.

\*3 Cooling mode/Heating mode

\*4 External static pressure option is available (30Pa/3.1mmH<sub>2</sub>O).

\*5 87 (192), for PUMY-CP100/125/140VKM2-BS.

\*Nominal conditions \*1 are subject to ISO 15042.

\*Due to continuing improvement, above specification may be subject to change without notice.

OUTDOOR UNIT

S-series

## PUMY-CP YKM (-BS)



Advantages of CITY MULTI

Outdoor unit

Indoor unit

Remote Controller

Lossnay

Model		PUMY-CP175YKM (-BS)	PUMY-CP200YKM (-BS)	PUMY-CP225YKM (-BS)
Power source		3-phase 380-400-415V 50Hz / 380V 60Hz		
Cooling capacity (Nominal)	*1 kW	20.0	22.4	25.0
	*1 BTU/h	68,200	76,400	85,300
	Power input kW	5.00	5.74	6.54
	Current input A	8.94-8.50-8.19 / 8.94	10.03-9.53-9.18 / 10.03	11.17-10.61-10.23 / 11.17
	EER kW/kW	4.00	3.90	3.82
Temp. range of cooling	Indoor temp. W.B.	15.0 to 24.0°C (59 to 75°F)		
	Outdoor temp. D.B.	10 to 52.0°C (50 to 126°F)		
Indoor unit connectable	Total capacity	50 to 150% of outdoor unit capacity *2		
	Model/ Quantity	CITY MULTI 15-200/12	15-250/12	15-250/12
Sound pressure level (measured in anechoic room)	*3 dB <A>	57/-	57/-	58/-
Refrigerant piping diameter	Liquid pipe mm (in.)	9.52 (3/8) Flare*4		
	Gas pipe mm (in.)	22.2 (7/8) Brazed		
Fan	Type x Quantity	Propeller Fan x 2		
	Air flow rate	m³/min	134	143.8
		L/s	2,233	2,397
		cfm	4,732	5,078
*5 Motor output kW	0.20 + 0.20			
Compressor	Type x Quantity	Scroll hermetic compressor x 1		
	Starting method	Inverter		
	Motor output kW	3.5	3.9	4.3
External finish		Galvanized Steel Sheet Munsell No. 3Y 7.8/1.1		
External dimension H x W x D	mm in.	1,338 x 1,050 x 330 (+25)		
		52-11/16 x 41-11/32 x 13 (+1)		
Protection devices	High pressure protection	High pressure switch		
	Inverter circuit (COMP./FAN)	Overcurrent detection, Overheat detection (Heat Sink thermistor)		
	Compressor	Compressor thermistor, Overcurrent detection		
	Fan motor	Overheating, Voltage protection		
Refrigerant	Type x original charge	R410A 6.3kg		
Net weight	kg (lbs)	129 (285) *6		
Heat exchanger		Cross Fin and Copper tube		
Defrosting method		Reversed refrigerant circuit		
Optional parts		Joint: CMY-Y62-G-E		

## Notes:

\*1 Nominal conditions

	Indoor	Outdoor	Pipe length	Level difference
Cooling	27°C DB/19°C WB (81°F DB/66°F WB)	35°C DB (95°F DB)	7.5m (24-9/16ft.)	0m (0ft.)

\*2 Up to 150% can be connected. However, up to 130% for simultaneous operation.

\*3 Cooling mode/Heating mode

\*4 Liquid pipe diameter: 12.7mm in case that the farthest piping length is longer than 60m, or piping length from outdoor unit to a branch box is longer than 20m.

\*5 External static pressure option for CP100/125/140 is available (30 Pa/3.1 mmH<sub>2</sub>O).

\*6 88 (195), for PUMY-CP100/125/140YKM2-BS. 130 (287) for PUMY-CP175/200/225YKM2-BS.

\*Nominal conditions \*1 are subject to ISO 15042.

\*Due to continuing improvement, above specification may be subject to change without notice.

OUTDOOR UNIT

**S-series**

**PUMY-CP YBM (-BS)**



**Specifications**

Model			PUMY-CP250YBM (-BS)	PUMY-CP300YBM (-BS)
Power source			3-phase 380-400-415 V, 50 Hz; 3-phase 380 V, 60 Hz	
Cooling capacity (Nominal)	*1	kW	28.0	33.5
	*1	BTU/h	95,500	114,300
		Power input	7.18	8.59
		Current input	11.73-11.14-10.74, 11.73	14.03-13.33-12.85, 14.03
		EER	3.90	3.90
Temp. range of cooling	Indoor temp.	W.B.	15.0 to 24.0°C (59 to 75°F)	
	Outdoor temp.	D.B.	10.0 to 52.0°C (50 to 126°F)	
Indoor unit connectable	Total capacity		50 to 150% of outdoor unit capacity *2	
	Model/Quantity	CITY MULTI	15-250/24	15-250/29
Sound pressure level (measured in anechoic room)		dB <A>	59	60
Refrigerant piping diameter	Liquid pipe	mm (in.)	9.52(3/8) Flared *5	12.7(1/2) Flared
	Gas pipe	mm (in.)	22.2(7/8) Brazed	25.4(1) Brazed
Fan	Type x Quantity		Propeller Fan x 2	
	Air flow rate	m³/min	178	178
		L/s	2,966	2,966
		cfm	6,285	6,285
	Motor output	0.375 + 0.375		
Compressor *3	Type x Quantity		Scroll hermetic compressor x 1	
	Starting method		Inverter	
		Motor output	6.77	7.59
External finish			Galvanized Steel Sheet Munsell No. 3Y 7.8/1.1	
External dimension H x W x D	mm		1,662 x 1,050 x 460 (+45)	
	in.		65-7/16 x 41-11/32 x 18-7/64 (+1-49/64)	
Protection devices	High pressure protection		High pressure switch	
	Inverter circuit		Overcurrent detection, Overheat detection (Heat Sink thermistor)	
	Compressor		Compressor thermistor, Overcurrent detection, Compressor protector	
	Fan motor		Overcurrent, Overheating, Voltage protection	
Refrigerant	Type x original charge		R410A 8.0kg	
Net weight		kg (lbs)	185(408) *4	
Heat exchanger			Micro-Slit Fin and Copper tube	
Defrosting method			-	
Optional parts			Joint: CMY-Y62-G-E	

**Notes:**

\*1 Nominal conditions

	Indoor	Outdoor	Pipe length	Level difference	External static press.
Cooling	27°C DB/19°C WB (81°F DB/66°F WB)	35°C DB (95°F DB)	7.5m (24-9/16ft.)	0m (0ft.)	0 Pa

\*2 Up to 150% can be connected. However, up to 130% for simultaneous operation.

\*3 External static pressure option is available (30 Pa/3.1 mmH<sub>2</sub>O).

\*4 187kg(413lbs) for PUMY-CP250/300YBM-BS.

\*5 Liquid pipe diameter: 12.7mm, in case of farthest piping length (farthest indoor unit from outdoor unit) is longer than 90m, or connect with PEFY-P200/250.

\*Nominal conditions \*1 are subject to ISO 15042.

\*Due to continuing improvement, above specification may be subject to change without notice.

OUTDOOR UNIT

S-series

## PUMY-SP VKM (-BS)



Advantages of CITY MULTI

Outdoor unit

Indoor unit

Remote Controller

Lossnay

## Specifications

Model	PUMY-SP100VKM (-BS)		PUMY-SP125VKM (-BS)		PUMY-SP140VKM (-BS)		
Power source	1-phase 220-230-240 V, 50 Hz; 1-phase 220 V, 60 Hz						
Cooling capacity (Nominal)	*1 kW	11.2	14.0	15.5			
	*1 BTU/h	38,214	47,768	52,886			
	Power input kW	2.78	3.84	4.70			
	Current input A	12.89-12.33-11.82, 12.89	17.81-17.04-16.33, 17.81	21.80-20.85-19.98, 21.80			
Temp. range of cooling	EER kW/kW	4.03	3.65	3.30			
	Indoor temp. W.B.	15 to 24°C (59 to 75°F)					
	Outdoor temp.*3*4 D.B.	-5 to 52°C (23 to 126°F)					
Heating capacity (Nominal)	*2 kW	12.5	16.0	16.5			
	*2 BTU/h	42,650	54,592	56,298			
	Power input kW	2.58	3.90	4.02			
	Current input A	11.97-11.45-10.97, 11.97	18.09-17.30-16.58, 18.09	18.65-17.83-17.09, 18.65			
Temp. range of heating	COP kW/kW	4.84	4.10	4.10			
	Indoor temp. D.B.	15 to 27°C (59 to 81°F)					
	Outdoor temp. W.B.	-20 to 15°C (-4 to 59°F)					
Indoor unit connectable	Total capacity	50 to 130% of outdoor unit capacity					
	Model/Quantity	CITY MULTI	15-125/7	15-140/10	15-140/12		
Sound pressure level (Cooling/Heating)*5	dB <A>	51/54	53/56	54/56			
Refrigerant piping diameter	Liquid pipe mm (in.)	9.52 (3/8) Flared					
	Gas pipe mm (in.)	15.88 (5/8) Flared					
Fan	Type x Quantity	Propeller Fan x 1					
	Air flow rate	m <sup>3</sup> /min	75	83	83		
		L/s	1,283	1,383	1,383		
		cfm	2,791	2,931	2,931		
*6 Motor output kW	0.20 x 1						
Compressor	Type x Quantity	Twin rotary hermetic compressor x 1					
	Starting method	Inverter					
	Motor output kW	2.7	3.5	3.7			
External finish	Galvanized Steel Sheet Munsell No. 3Y 7.8/1.1						
External dimension H x W x D	mm	981 x 1050 x 330 (+25)					
	in.	38-5/8 x 41-3/8 x 13 (+1)					
Protection devices	High pressure protection	High pressure switch					
	Inverter circuit (COMP./FAN)	Overcurrent detection, Overheat detection (Heat Sink thermistor)					
	Compressor	Compressor thermistor, Overcurrent detection					
	Fan motor	Overheating, Voltage protection					
Refrigerant	Type x original charge	R410A 3.5kg					
Net weight	kg (lbs)	93 (205) *7					
Heat exchanger	Cross Fin and Copper tube						
Defrosting method	Reversed refrigerant circuit						
Optional parts	Joint: CMY-Y62-G-E, Air protect guide:PAC-SH95AG-E						

## Notes:

\*1, \*2 Nominal conditions

	Indoor	Outdoor	Pipe length	Level difference
Cooling	27°C DB/19°C WB (81°F DB/66°F WB)	35°C DB (95°F DB)	7.5m (24-9/16ft.)	0m (0ft.)
Heating	20°C DB (68°F DB)	7°C DB/6°C WB (45°F DB/43°F WB)	7.5m (24-9/16ft.)	0m (0ft.)

\*3 10 to 52°C D.B. [50 to 126°F D.B.], when connecting following models: PKFY-P15/20/25/32VLM, PFFY-P20/25/32VLEM, PFFY-P20/25/32VLRM(M), PFFY-P20/25/32VCM, PFFY-P20/25/32VKM, and M-Series, S-Series, and P-Series type indoor unit with branch box, M-Series type indoor unit with connection kit.

\*4 -15 to 52°C D.B. [5 to 126°F D.B.], when using an optional air protect guide [PAC-SH95AG-E]. However, this condition does not apply to the indoor unit listed in\*3.

\*5 Cooling mode/Heating mode

\*6 External static pressure option is available (30 Pa/3.1 mmH<sub>2</sub>O).

\*7 94 (207), for PUMY-SP100/125/140VKM-BS. 95 (209), for PUMY-SP100/125/140YKM-BS.

\*Nominal conditions \*1,\*2 are subject to ISO 15042.

\*Due to continuing improvement, above specification may be subject to change without notice.

OUTDOOR UNIT

S-series

PUMY-P YKM (-BS)



Specifications

Model	PUMY-P175YKM (-BS)	PUMY-P200YKM (-BS)	PUMY-P225YKM (-BS)		
Power source	3-phase 380-400-415V 50Hz/ 380V 60Hz				
Cooling capacity (Nominal)	*1 kW	20.0	22.4	25.0	
	*1 BTU/h	68,200	76,400	85,300	
	Power input kW	5.00	5.74	6.54	
	Current input A	8.94 - 8.50 - 8.19 / 8.94	10.03 - 9.53 - 9.18 / 10.03	11.17 - 10.61 - 10.23 / 11.17	
	EER kW/kW	4.00	3.90	3.82	
Temp. range of cooling	Indoor temp. W.B.	15.0 to 24.0°C (59 to 75°F)			
	Outdoor temp. *3*4 D.B.	-5.0 to 52.0°C (23 to 126°F)			
Heating capacity (Nominal)	*2 kW	22.4	25.0	27.3	
	*2 BTU/h	76,400	85,300	93,200	
	Power input kW	5.14	5.99	6.80	
	Current input A	9.19 - 8.73 - 8.42 / 9.19	10.47 - 9.94 - 9.58 / 10.47	11.61 - 11.03 - 10.63 / 11.61	
	COP kW/kW	4.35	4.17	4.01	
Temp. range of heating	Indoor temp. D.B.	15.0 to 27.0°C (59 to 81°F)			
	Outdoor temp. W.B.	-20.0 to 15.0°C (-4 to 59°F)			
Indoor unit connectable	Total capacity	50 to 130% of outdoor unit capacity			
	Model/Quantity	CITY MULTI	15 - 200/12	15 - 250/12	15 - 250/12
Sound pressure level (measured in anechoic room)	dB <A>	57/61	57/61	58/63	
Refrigerant piping diameter	Liquid pipe mm (in.)	9.52 (3/8) Flare *5			
	Gas pipe mm (in.)	22.2 (7/8) Brazed			
Fan	Type x Quantity	Propeller Fan x 2			
	Air flow rate	m <sup>3</sup> /min	134	134	143.8
		L/s	2,233	2,233	2,397
		cfm	4,732	4,732	5,078
Motor output	kW	0.20 + 0.20			
Compressor	Type x Quantity	Scroll hermetic compressor x 1			
	Starting method	Inverter			
	Motor output	4.3	5.2	5.4	
External finish		Galvanized Steel Sheet Munsell No. 3Y 7.8/1.1			
External dimension H x W x D	mm	1,338 x 1,050 x 330 (+25)			
	in.	52-11/16 x 41-11/32 x 13 (+1)			
Protection devices	High pressure protection	High pressure switch			
	Inverter circuit (COMP./FAN)	Overcurrent detection, Overheat detection (Heat sink thermistor)			
	Compressor	Compressor thermistor, Overcurrent detection			
	Fan motor	Overheating, Voltage protection			
Refrigerant	Type x original charge	R410A 7.3kg			
Net weight	kg (lbs)	138 (305) *6			
Heat exchanger		Cross Fin and Copper tube			
Defrosting method		Reversed refrigerant circuit			
Optional parts		Joint: CMY-Y62-G-E			

Notes:

\*1,\*2 Nominal conditions

	Indoor	Outdoor	Pipe length	Level difference
Cooling	27°C DB/19°C WB (81°F DB/66°F WB)	35°C DB (95°F DB)	7.5m (24-9/16ft.)	0m (0ft.)
Heating	20°C DB (68°F DB)	7°C DB/6°C WB (45°F DB/43°F WB)	7.5m (24-9/16ft.)	0m (0ft.)

\*3 10 to 52°C D.B. : When connecting PKFY-P15/20/25/32VLM, PFFY-P20/25/32VKM, PFFY-P20/25/32VLEM, PFFY-P20/25/32VLRM(M), PFFY-P20/25/32VCM, PEFY-P-VMA3, M, S and P series indoor unit.

\*4 -15 to 52°C D.B. [5 to 126°F D.B.], when using an optional air protect guide [PAC-SH95AG-E]. However, this condition does not apply to the indoor unit listed in\*3.

\*5 Liquid pipe diameter: 12.7mm in case that the farthest piping length is longer than 60m, or piping length from outdoor unit to a branch box is longer than 20m.

\*6 139 (306) for PUMY-P175/200/225YKM2-BS.

\*Nominal conditions \*1,\*2 are subject to ISO 15042.

\*Due to continuing improvement, above specification may be subject to change without notice.

OUTDOOR UNIT

S-series

## PUMY-P YBM (-BS)



Advantages of CITY MULTI

Outdoor unit

Indoor unit

Remote Controller

Lossnay

## Specifications

Model	PUMY-P250YBM (-BS)		PUMY-P300YBM (-BS)	
Power source	3-phase 380-400-415 V, 50 Hz; 3-phase 380 V, 60 Hz			
Cooling capacity (Nominal)	*1 kW	28.0		33.5
	*1 BTU/h	95,500		114,300
Power input	kW	6.83		8.17
	A	11.16-10.60-10.22, 11.16		13.35-12.68-12.22, 13.35
	kW/kW	4.10		4.10
Temp. range of cooling	Indoor temp. W.B.	15.0 to 24.0°C (59 to 75°F)		
	Outdoor temp.*3*4 D.B.	-5.0~52.0°C (23 to 126°F)		
Heating capacity (Nominal)	*2 kW	31.5		37.5
	*2 BTU/h	107,400		127,900
	kW	6.06		7.36
	A	9.90-9.41-9.07, 9.90		12.02-11.42-11.01, 12.02
Temp. range of heating	COP	5.20		5.10
	Indoor temp. D.B.	15.0 to 27.0°C (59 to 81°F)		
Indoor unit connectable	Outdoor temp. W.B.	-20.0 to 15.0°C (-4 to 59°F)		
	Total capacity	50 to 130% of outdoor unit capacity		
Sound pressure level (measured in anechoic room)	Model/Quantity	CITY MULTI		
	Quantity	15-250/21		15-250/25
Refrigerant piping diameter	Liquid pipe mm (in.)	9.52(3/8) Flared *8		12.7(1/2) Flared
	Gas pipe mm (in.)	22.2(7/8) Brazed		25.4(1) Brazed
Fan	Type x Quantity	Propeller Fan x 2		
	Air flow rate	m <sup>3</sup> /min	187/183	187/197
		L/s	3116/3050	3116/3283
		cfm	6603/6462	6603/6956
*5 Motor output	kW	0.375 + 0.375		
Compressor	Type x Quantity	Scroll hermetic compressor x 1		
	Starting method	Inverter		
*6 Motor output	kW	6.65		7.35
External finish	Galvanized Steel Sheet Munsell No. 3Y 7.8/1.1			
	External dimension H x W x D	mm	1,662 x 1,050 x 460 (+45)	
Protection devices	High pressure protection	High pressure switch		
	Inverter circuit (COMP./FAN)	Overcurrent detection, Overheat detection (Heat Sink thermistor)		
	Compressor	Compressor thermistor, Overcurrent detection, Compressor protector		
	Fan motor	Overcurrent, Overheating, Voltage protection		
Refrigerant	Type x original charge	R410A 9.3kg		
Net weight	kg (lbs)	192 (424) *7		
Heat exchanger	Ring Fin and Copper tube			
Defrosting method	Reversed refrigerant circuit			
Optional parts	Joint: CMY-Y62-G-E			

## Notes:

\*1, \*2 Nominal conditions

	Indoor	Outdoor	Pipe length	Level difference	External static press.
Cooling	27°C DB/19°C WB (81°F DB/66°F WB)	35°C DB (95°F DB)	7.5m (24-9/16ft.)	0m (0ft.)	0 Pa
Heating	20°C DB	7°C DB/6°C WB (45°F DB/43°F WB)	7.5m (24-9/16ft.)	0m (0ft.)	0 Pa

\*3 10 to 52°C D.B. : When connecting PKFY-P15/20/25/32VLM, PFFY-P20/25/32VKM, PFFY-P20/25/32VLEM, PFFY-P20/25/32VLRM(M), PFFY-P20/25/32VCM, PEFY-P-VMA3, M, S and P series indoor unit.

\*4 -15 to 52°C D.B. [5 to 126°F D.B.], when using an optional air protect guide [PAC-SH21AG-E]. However, this condition does not apply to the indoor unit listed in\*3.

\*5 Cooling mode/Heating mode

\*6 External static pressure option is available (30 Pa/3.1 mmH<sub>2</sub>O).

\*7 194 (428) for PUMY-P250/300YBM-BS.

\*8 Liquid pipe diameter: 12.7mm, in case of farthest piping length (farthest indoor unit from outdoor unit) is longer than 90m, or connect with PEFY-P200/250.

\*Nominal conditions \*1,\*2 are subject to ISO 15042.

\*Due to continuing improvement, above specification may be subject to change without notice.

OUTDOOR UNIT

**YKD-series - Cooling-only**

**PUCY-P YKD (-BS)**



Model			PUCY-P200YKD (-BS)	PUCY-P250YKD (-BS)	PUCY-P300YKD (-BS)	PUCY-P350YKD (-BS)
Power source			3-phase 4-wire 380-400-415 V 50/60 Hz	3-phase 4-wire 380-400-415 V 50/60 Hz	3-phase 4-wire 380-400-415 V 50/60 Hz	3-phase 4-wire 380-400-415 V 50/60 Hz
Cooling capacity (Nominal)	*1	kW	22.4	28.0	33.5	40.0
		kcal/h	20,000	25,000	30,000	35,000
		BTU/h	76,400	95,500	114,300	136,500
	Power input	kW	4.66	5.95	7.82	9.66
		A	7.8-7.4-7.2	10.0-9.5-9.1	13.2-12.5-12.0	16.3-15.4-14.9
EER	kW/kW	4.80	4.70	4.28	4.14	
Temp. range of cooling	Indoor	W.B.	15.0~24.0 °C (59~75 °F)	15.0~24.0 °C (59~75 °F)	15.0~24.0 °C (59~75 °F)	15.0~24.0 °C (59~75 °F)
	Outdoor	D.B.	10.0~52.0 °C (50~126 °F)	10.0~52.0 °C (50~126 °F)	10.0~52.0 °C (50~126 °F)	10.0~52.0 °C (50~126 °F)
Sound pressure level (measured in anechoic room)		dB <A>	57	58	61	61
Refrigerant piping diameter	Liquid pipe	mm (in.)	9.52 (3/8) Brazed	9.52 (3/8) Brazed (12.7 (1/2) Brazed, farthest length >= 90 m)	9.52 (3/8) Brazed (12.7 (1/2) Brazed, farthest length >= 40 m)	12.7 (1/2) Brazed
	Gas pipe	mm (in.)	22.2 (7/8) Brazed	22.2 (7/8) Brazed	22.2 (7/8) Brazed	28.58 (1-1/8) Brazed
Fan	Air flow rate	cfm	6,179	6,179	6,179	7,415
External finish			Pre-coated galvanized steel sheets (+powder coating for -BS type) <MUNSELL 3Y 7.8/1.1 or similar>	Pre-coated galvanized steel sheets (+powder coating for -BS type) <MUNSELL 3Y 7.8/1.1 or similar>	Pre-coated galvanized steel sheets (+powder coating for -BS type) <MUNSELL 3Y 7.8/1.1 or similar>	Pre-coated galvanized steel sheets (+powder coating for -BS type) <MUNSELL 3Y 7.8/1.1 or similar>
External dimension H x W x D			mm 1,650 x 920 x 740	mm 1,650 x 920 x 740	mm 1,650 x 920 x 740	mm 1,650 x 1,220 x 740
Refrigerant	Type x original charge		R410A x 5.5 kg (13 lbs)	R410A x 6.5 kg (15 lbs)	R410A x 6.5 kg (15 lbs)	R410A x 11.5 kg (26 lbs)
Net weight		kg (lbs)	174 (384)	183 (404)	200 (441)	236 (521)
Heat exchanger			Salt-resistant cross fin & copper tube	Salt-resistant cross fin & copper tube	Salt-resistant cross fin & copper tube	Salt-resistant cross fin & copper tube

Model			PUCY-P400YKD (-BS)	PUCY-P450YKD (-BS)	PUCY-P500YKD (-BS)
Power source			3-phase 4-wire 380-400-415 V 50/60 Hz	3-phase 4-wire 380-400-415 V 50/60 Hz	3-phase 4-wire 380-400-415 V 50/60 Hz
Cooling capacity (Nominal)	*1	kW	44.0	48.0	56.0
		kcal/h	39,000	43,000	50,000
		BTU/h	150,100	163,800	191,100
	Power input	kW	12.42	14.32	16.51
		A	20.9-19.9-19.1	24.1-22.9-22.1	27.8-26.4-25.5
EER	kW/kW	3.54	3.35	3.39	
Temp. range of cooling	Indoor	W.B.	15.0~24.0 °C (59~75 °F)	15.0~24.0 °C (59~75 °F)	15.0~24.0 °C (59~75 °F)
	Outdoor	D.B.	10.0~52.0 °C (50~126 °F)	10.0~52.0 °C (50~126 °F)	10.0~52.0 °C (50~126 °F)
Sound pressure level (measured in anechoic room)		dB <A>	63	63	65
Refrigerant piping diameter	Liquid pipe	mm (in.)	12.7 (1/2) Brazed	15.88 (5/8) Brazed	15.88 (5/8) Brazed
	Gas pipe	mm (in.)	28.58 (1-1/8) Brazed	28.58 (1-1/8) Brazed	28.58 (1-1/8) Brazed
Fan	Air flow rate	cfm	7,415	7,415	11,299
External finish			Pre-coated galvanized steel sheets (+powder coating for -BS type) <MUNSELL 3Y 7.8/1.1 or similar>	Pre-coated galvanized steel sheets (+powder coating for -BS type) <MUNSELL 3Y 7.8/1.1 or similar>	Pre-coated galvanized steel sheets (+powder coating for -BS type) <MUNSELL 3Y 7.8/1.1 or similar>
External dimension H x W x D			mm 1,650 x 1,220 x 740	mm 1,650 x 1,220 x 740	mm 1,650 x 1,750 x 740
Refrigerant	Type x original charge		R410A x 11.5 kg (26 lbs)	R410A x 11.5 kg (26 lbs)	R410A x 11.8 kg (27 lbs)
Net weight		kg (lbs)	236 (521)	236 (521)	304 (671)
Heat exchanger			Salt-resistant cross fin & copper tube	Salt-resistant cross fin & copper tube	Salt-resistant cross fin & copper tube

\*1 Nominal cooling conditions (subject to JIS B8615-2)

	Indoor	Outdoor	Pipe length	Level difference
Cooling	27 °CD.B./19 °CW.B. (81 °FD.B./66 °FW.B.)	35 °CD.B. (95 °FD.B.)	7.5 m (24-9/16 ft.)	0 m (0 ft.)

\*Due to continuing improvement, above specifications may be subject to change without notice.

\*(-BS) models have special salt resistant feature.

OUTDOOR UNIT  
**YKD-series**

**PUHY-P YKD (-BS)**



Advantages of CITY MULTI

Outdoor unit

Model		PUHY-P200YKD (-BS)	PUHY-P250YKD (-BS)	PUHY-P300YKD (-BS)	PUHY-P350YKD (-BS)
Power source		3-phase 4-wire 380-400-415 V 50/60 Hz	3-phase 4-wire 380-400-415 V 50/60 Hz	3-phase 4-wire 380-400-415 V 50/60 Hz	3-phase 4-wire 380-400-415 V 50/60 Hz
Cooling capacity (Nominal)	*1 kW	22.4	28.0	33.5	40.0
	kcal/h	20,000	25,000	30,000	35,000
	BTU/h	76,400	95,500	114,300	136,500
Power input	kW	4.48	5.88	7.59	9.66
	Current input A	7.5-7.1-6.9	9.9-9.4-9.0	12.8-12.1-11.7	16.3-15.4-14.9
	EER kW/kW	5.00	4.76	4.41	4.14
Temp. range of cooling	Indoor W.B.	15.0~24.0 °C (59~75 °F)	15.0~24.0 °C (59~75 °F)	15.0~24.0 °C (59~75 °F)	15.0~24.0 °C (59~75 °F)
	Outdoor D.B.	-5.0~52.0 °C (23~126 °F)	-5.0~52.0 °C (23~126 °F)	-5.0~52.0 °C (23~126 °F)	-5.0~52.0 °C (23~126 °F)
Heating capacity (Nominal)	*2 kW	22.4	28.0	33.5	40.0
	kcal/h	20,000	25,000	30,000	35,000
	BTU/h	76,400	95,500	114,300	136,500
Power input	kW	5.05	6.33	8.11	9.61
	Current input A	8.5-8.0-7.8	10.6-10.1-9.7	13.6-13.0-12.5	16.2-15.4-14.8
	COP kW/kW	4.43	4.42	4.13	4.16
Temp. range of heating	Indoor D.B.	15.0~27.0 °C (59~81 °F)	15.0~27.0 °C (59~81 °F)	15.0~27.0 °C (59~81 °F)	15.0~27.0 °C (59~81 °F)
	Outdoor W.B.	-20.0~15.5 °C (-4~60 °F)	-20.0~15.5 °C (-4~60 °F)	-20.0~15.5 °C (-4~60 °F)	-20.0~15.5 °C (-4~60 °F)
Sound pressure level (measured in anechoic room)	dB <A>	57	58	61	61
Refrigerant piping diameter	Liquid pipe mm (in.)	9.52 (3/8) Brazed	9.52 (3/8) Brazed (12.7 (1/2) Brazed, farthest length >= 90 m)	9.52 (3/8) Brazed (12.7 (1/2) Brazed, farthest length >= 40 m)	12.7 (1/2) Brazed
	Gas pipe mm (in.)	22.2 (7/8) Brazed	22.2 (7/8) Brazed	22.2 (7/8) Brazed	28.58 (1-1/8) Brazed
Fan	Air flow rate cfm	6,179	6,179	6,532	7,415
External finish		Pre-coated galvanized steel sheets (+powder coating for -BS type) <MUNSELL 3Y 7.8/1.1 or similar>	Pre-coated galvanized steel sheets (+powder coating for -BS type) <MUNSELL 3Y 7.8/1.1 or similar>	Pre-coated galvanized steel sheets (+powder coating for -BS type) <MUNSELL 3Y 7.8/1.1 or similar>	Pre-coated galvanized steel sheets (+powder coating for -BS type) <MUNSELL 3Y 7.8/1.1 or similar>
External dimension H x W x D mm		1,650 x 920 x 740	1,650 x 920 x 740	1,650 x 920 x 740	1,650 x 1,220 x 740
Refrigerant	Type x original charge	R410A x 8.0 kg (18 lbs)	R410A x 8.0 kg (18 lbs)	R410A x 8.0 kg (18 lbs)	R410A x 11.5 kg (26 lbs)
Net weight	kg (lbs)	191 (422)	191 (422)	204 (450)	243 (536)
Heat exchanger		Salt-resistant cross fin & copper tube	Salt-resistant cross fin & copper tube	Salt-resistant cross fin & copper tube	Salt-resistant cross fin & copper tube

Indoor unit

Remote Controller

Lossnay

Model		PUHY-P400YKD (-BS)	PUHY-P450YKD (-BS)	PUHY-P500YKD (-BS)
Power source		3-phase 4-wire 380-400-415 V 50/60 Hz	3-phase 4-wire 380-400-415 V 50/60 Hz	3-phase 4-wire 380-400-415 V 50/60 Hz
Cooling capacity (Nominal)	*1 kW	45.0	48.0	55.0
	kcal/h	40,000	43,000	49,000
	BTU/h	153,500	163,800	187,700
Power input	kW	12.71	14.32	16.22
	Current input A	21.4-20.3-19.6	24.1-22.9-22.1	27.3-26.0-25.0
	EER kW/kW	3.54	3.35	3.39
Temp. range of cooling	Indoor W.B.	15.0~24.0 °C (59~75 °F)	15.0~24.0 °C (59~75 °F)	15.0~24.0 °C (59~75 °F)
	Outdoor D.B.	-5.0~52.0 °C (23~126 °F)	-5.0~52.0 °C (23~126 °F)	-5.0~52.0 °C (23~126 °F)
Heating capacity (Nominal)	*2 kW	45.0	48.0	55.0
	kcal/h	40,000	43,000	49,000
	BTU/h	153,500	163,800	187,700
Power input	kW	10.92	13.33	15.71
	Current input A	18.4-17.5-16.8	22.5-21.3-20.6	26.5-25.1-24.2
	COP kW/kW	4.12	3.60	3.50
Temp. range of heating	Indoor D.B.	15.0~27.0 °C (59~81 °F)	15.0~27.0 °C (59~81 °F)	15.0~27.0 °C (59~81 °F)
	Outdoor W.B.	-20.0~15.5 °C (-4~60 °F)	-20.0~15.5 °C (-4~60 °F)	-20.0~15.5 °C (-4~60 °F)
Sound pressure level (measured in anechoic room)	dB <A>	63	63	65
Refrigerant piping diameter	Liquid pipe mm (in.)	12.7 (1/2) Brazed	15.88 (5/8) Brazed	15.88 (5/8) Brazed
	Gas pipe mm (in.)	28.58 (1-1/8) Brazed	28.58 (1-1/8) Brazed	28.58 (1-1/8) Brazed
Fan	Air flow rate cfm	7,415	7,415	12,712
External finish		Pre-coated galvanized steel sheets (+powder coating for -BS type) <MUNSELL 3Y 7.8/1.1 or similar>	Pre-coated galvanized steel sheets (+powder coating for -BS type) <MUNSELL 3Y 7.8/1.1 or similar>	Pre-coated galvanized steel sheets (+powder coating for -BS type) <MUNSELL 3Y 7.8/1.1 or similar>
External dimension H x W x D mm		1,650 x 1,220 x 740	1,650 x 1,220 x 740	1,650 x 1,750 x 740
Refrigerant	Type x original charge	R410A x 11.5 kg (26 lbs)	R410A x 11.5 kg (26 lbs)	R410A x 11.8 kg (27 lbs)
Net weight	kg (lbs)	241 (532)	241 (532)	285 (629)
Heat exchanger		Salt-resistant cross fin & copper tube	Salt-resistant cross fin & copper tube	Salt-resistant cross fin & copper tube

\*1,\*2 Nominal conditions

	Indoor	Outdoor	Pipe length	Level difference
Cooling	27 °CD.B./19 °CW.B. (81 °FD.B./66 °FW.B.)	35 °CD.B. (95 °FD.B.)	7.5 m (24-9/16 ft.)	0 m (0 ft.)
Heating	20 °CD.B. (68 °FD.B.)	7 °CD.B./6 °CW.B. (45 °FD.B./43 °FW.B.)	7.5 m (24-9/16 ft.)	0 m (0 ft.)

\*Nominal condition \*1,\*2 are subject to JIS B8615-2.

\*Due to continuing improvement, above specifications may be subject to change without notice.

\*(-BS) models have special salt resistant feature.

# Indoor Units

## Ceiling Cassette Type

**4-way airflow type**  
**PLFY-P VEM**



**Capacity zone**

kW	3.6	4.5	5.6	7.1	9.0	11.2	14.0	16.0
----	-----	-----	-----	-----	-----	------	------	------

Office Hospital School Restaurant

»» P 35

**4-way compact airflow type**  
**PLFY-P VFM**



**Capacity zone**

kW	1.7	2.2	2.8	3.6	4.5	5.6
----	-----	-----	-----	-----	-----	-----

Office Hospital School Restaurant

»» P 36

**2-way airflow type**  
**PLFY-P VLMD**



**Capacity zone**

kW	2.2	2.8	3.6	4.5	5.6	7.1	9.0	11.2
----	-----	-----	-----	-----	-----	-----	-----	------

Office Hospital School Residence

»» P 37

**1-way airflow type**  
**PMFY-P VBM**  
**PMFY-P VFM**

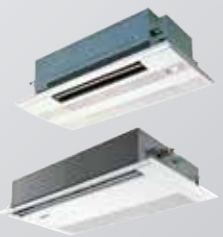

**Capacity zone**

kW	2.2	2.8	3.6	4.5	5.6	7.1	8.0	9.0
----	-----	-----	-----	-----	-----	-----	-----	-----

Office School Restaurant Residence

»» P 38

## Ceiling Concealed Type

**Low static pressure type**  
**PEFY-P VMS1(L)**



**Capacity zone**

kW	1.7	2.2	2.8	3.6	4.5	5.6	7.1
----	-----	-----	-----	-----	-----	-----	-----

Office Residence Restaurant Hotel

»» P 39

**Medium static pressure type**  
**PEFY-P VMA(L)**



**Capacity zone**

VMA(L) (kW)	2.2	2.8	3.6	4.5	5.6	7.1	8.0	9.0	11.2	14.0	16.0
-------------	-----	-----	-----	-----	-----	-----	-----	-----	------	------	------

Office School Residence Hotel

»» P 40

**High static pressure type**  
**PEFY-P VMHS-E**



**Capacity zone**

kW	4.5	5.6	7.1	8.0	9.0	11.2	14.0	16.0	22.4	28.0
----	-----	-----	-----	-----	-----	------	------	------	------	------

Office Hospital School Restaurant

»» P 41

**Fresh air intake type**  
**PEFY-P VMHS-E-F**



**Capacity zone**

kW	14.0	22.4	28.0
----	------	------	------

Office Hospital School Restaurant

»» P 42

**Ceiling suspended type**  
**PCFY-P VKM**



**Capacity zone**

kW	4.5	7.1	11.2	14.0
----	-----	-----	------	------



»»» P 43

**Wall-mounted type**  
**PKFY-P VLM**  
**PKFY-P VKM**



**Capacity zone**

VLM (kW)	1.7	2.2	2.8	3.6	4.5	5.6
VKM (kW)	7.1	11.2				



»»» P 44

**Floor standing type**  
**PFFY-P VKM**



**Capacity zone**

kW	2.2	2.8	3.6	4.5
----	-----	-----	-----	-----



»»» P 45

**Floor standing type (for perimeter zone)**  
**PFFY-P VLEM**



**Capacity zone**

kW	2.2	2.8	3.6	4.5	5.6	7.1
----	-----	-----	-----	-----	-----	-----



»»» P 45

**Floor standing type (for perimeter zone)**  
**PFFY-P VCM**



**Capacity zone**

kW	2.2	2.8	3.6	4.5	5.6	7.1
----	-----	-----	-----	-----	-----	-----

»»» P 46

**Floor standing type**  
**PFFY-P YM**  
**PFFY-P YMH**



**Capacity zone**

YM (kW)	22.4	28.0	45.0	56.0
YMH (kW)	22.4	28.0		



»»» P 47

**AHU KIT**

**PAC-AH M**

**Capacity zone**

kW	11.2	14.0	16.0	22.4	28.0	45.0	56.0
----	------	------	------	------	------	------	------



»»» P 48

**Branch Box System**

**PAC-MK BC**  
**MSXY-MP VA**  
**MSXZ-MP VA**  
**MSXZ-FP VA**



**Capacity zone**

kW	2.5	3.5	3.6	5.2	6.6
----	-----	-----	-----	-----	-----



»»» P 49

# 4-way airflow cassette type

## PLFY-P VEM



Model		PLFY-P32VEM	PLFY-P40VEM	PLFY-P50VEM	PLFY-P63VEM	
Power source		1-phase 220-240V 50Hz/1-phase 220-230V 60Hz				
Cooling capacity	*1 kW	3.6	4.5	5.6	7.1	
	*1 BTU/h	12,300	15,400	19,100	24,200	
	Power input kW	0.03	0.03	0.03	0.03	
	Current input A	0.32	0.32	0.32	0.36	
Heating capacity	*2 kW	4.0	5.0	6.3	8.0	
	*2 BTU/h	13,600	17,100	21,500	27,300	
	Power input kW	0.03	0.03	0.03	0.03	
	Current input A	0.25	0.25	0.25	0.29	
External finish (Munsell No.)	Unit	Galvanized steel sheet				
	Panel	MUNSELL (1.0Y 9.2/0.2)				
External dimension H x W x D	Unit	258 x 840 x 840				
	Panel	40 x 950 x 950				
Net weight	Unit	19			21	
	Panel	5				
Heat exchanger		Micro slit fin (Aluminumfin and copper tube)				
Fan	Type x Quantity		Turbo fan x 1			
	Airflow rate (Low-Mid2-Mid1-High)	m <sup>3</sup> /min	13-14-16-17	13-14-16-18	13-14-16-19	15-16-17-19
		L/s	217-233-267-283	217-233-267-300	217-233-267-317	250-267-283-317
		cfm	459-494-565-600	459-494-565-636	459-494-565-671	530-565-600-671
External static pressure	Pa	0				
Motor	Type	DC motor				
	Output	0.050				
Air filter		PP honeycomb				
Sound pressure level (Low-Mid2-Mid1-High)	dB (A)	26-27-29-31	26-27-29-31	26-27-29-31	28-29-30-32	
Refrigerant control device		LEV				
Diameter of refrigerant pipe	Liquid	ø6.35 (ø 1/4) Flare			ø9.52 (ø 3/8) Flare	
	Gas	ø12.7 (ø 1/2) Flare			ø15.88 (ø 5/8) Flare	
Field drain pipe size	mm (in.)	O.D 32 (1-1/4)				

Model		PLFY-P80VEM	PLFY-P100VEM	PLFY-P125VEM	PLFY-P140VEM	
Power source		1-phase 220-240V 50Hz/1-phase 220-230V 60Hz				
Cooling capacity	*1 kW	9.0	11.2	14.0	16.0	
	*1 BTU/h	30,700	38,200	47,800	54,600	
	Power input kW	0.05	0.07	0.11	0.11	
	Current input A	0.50	0.67	1.06	1.06	
Heating capacity	*2 kW	10.0	12.5	16.0	18.0	
	*2 BTU/h	34,100	42,700	54,600	61,400	
	Power input kW	0.05	0.07	0.11	0.11	
	Current input A	0.43	0.60	0.99	0.99	
External finish (Munsell No.)	Unit	Galvanized steel sheet				
	Panel	MUNSELL (1.0Y 9.2/0.2)				
External dimension H x W x D	Unit	258 x 840 x 840	298 x 840 x 840			
	Panel	40 x 950 x 950				
Net weight	Unit	21	24		26	
	Panel	5				
Heat exchanger		Micro slit fin (Aluminumfin and copper tube)				
Fan	Type x Quantity		Turbo fan x 1			
	Airflow rate (Low-Mid2-Mid1-High)	m <sup>3</sup> /min	15-18-20-23	20-23-26-29	24-26-30-35	22-27-31-35
		L/s	250-300-333-383	333-383-433-483	400-433-500-583	367-450-517-583
		cfm	530-636-706-812	706-812-918-1024	847-918-1060-1236	777-953-1095-1235
External static pressure	Pa	0				
Motor	Type	DC motor				
	Output	0.050	0.120			
Air filter		PP honeycomb				
Sound pressure level (Low-Mid2-Mid1-High)	dB (A)	28-31-34-37	34-37-39-41	35-39-42-45	36-39-42-45	
Refrigerant control device		LEV				
Diameter of refrigerant pipe	Liquid	ø9.52 (ø 3/8) Flare				
	Gas	ø15.88 (ø 5/8) Flare				
Field drain pipe size	mm (in.)					

### Notes:

\*1. Nominal cooling conditions  
 Indoor: 27°C.D.B./19°C.W.B. (81°F.D.B./66°F.W.B.), Outdoor: 35°C.D.B. (95°F.D.B.)  
 Pipe length: 7.5 m (24-9/16 ft.), Level difference: 0 m (0 ft.)

\*2. Nominal heating conditions  
 Indoor: 20°C.D.B. (68°F.D.B.), Outdoor: 7°C.D.B./6°C.W.B. (45°F.D.B./43°F.W.B.)  
 Pipe length: 7.5 m (24-9/16 ft.), Level difference: 0 m (0 ft.)

# 4-way airflow cassette type

## PLFY-P VFM



### Specifications

Model		PLFY-P15VFM	PLFY-P20VFM	PLFY-P25VFM	PLFY-P32VFM	PLFY-P40VFM	PLFY-P50VFM	
Power source		1-phase 220-240V 50Hz/220V 60Hz						
Cooling capacity	*1 kW	1.7	2.2	2.8	3.6	4.5	5.6	
	*1 BTU/h	5,800	7,500	9,600	12,300	15,400	19,100	
Heating capacity	*1 kW	1.9	2.5	3.2	4.0	5.0	6.3	
	*1 BTU/h	6,500	8,500	10,900	13,600	17,100	21,500	
Power consumption	Cooling kW	0.02	0.02	0.02	0.02	0.03	0.04	
	Heating kW	0.02	0.02	0.02	0.02	0.03	0.04	
Current	Cooling A	0.19	0.21	0.22	0.23	0.28	0.40	
	Heating A	0.14	0.16	0.17	0.18	0.23	0.35	
External finish (Munsell No.)	Unit	Galvanized steel sheet						
	Panel	MUNSELL (1.0Y 9.2/0.2)						
Panel Model	SLP-2FAL							
Dimension H x W x D	Unit	208 x 570 x 570 (8-1/4 x 22-1/2 x 22-1/2)						
	Panel	10 x 625 x 625 (3/8 x 24-5/8 x 24-5/8)						
Net weight	Unit	14 (31)			15 (33)			
	Panel	3 (7)						
Heat exchanger	Cross fin (Aluminum fin and copper tube)							
Fan	Type x Quantity	Turbo fan x 1						
	Airflow rate (Lo-Mid-Hi)	m <sup>3</sup> /min	6.5-7.5-8.0	6.5-7.5-8.5	6.5-8.0-9.0	7.0-8.0-9.5	7.5-9.0-11.0	9.0-11.0-13.0
		cfm	230-265-282	230-265-300	230-282-318	247-282-335	265-318-388	318-388-459
External static pressure	Pa	0						
Motor	Type	DC motor						
	Output	0.05						
Air filter	PP Honeycomb fabric (long life type)							
Refrigerant pipe diameter	Gas (Flare)	ø12.7 (ø1/2)						
	Liquid (Flare)	ø6.35 (ø1/4)						
Field drain pipe diameter	mm (in.) O.D. 32 (1-1/4) (PVC pipe VP-25 connectable)							
Sound pressure level (Lo-Mid-Hi)	*2 dB (A)	26-28-30	26-29-31	26-30-33	26-30-34	28-33-39	33-39-43	

### Optional Parts

Description	Model	Applicable models
i-see Sensor corner panel	PAC-SF1ME	P15, P20, P25, P32, P40, P50
Wireless signal receiver	PAR-SF9FA	P15, P20, P25, P32, P40, P50

#### Notes:

- \*1 Cooling/Heating capacity indicates the maximum value at operation under the following condition.  
 Cooling : Indoor 27°C(81°F)DB/19°C(66°F)WB, Outdoor 35°C(95°F)DB  
 Heating : Indoor 20°C(68°F)DB, Outdoor 7°C(45°F)DB/6°C(43°F)WB  
 \*2 It is measured in anechoic room at power source 230V.

# 2-way airflow cassette type

## PLFY-P VLMD



Model			PLFY-P20VLMD	PLFY-P25VLMD	PLFY-P32VLMD	PLFY-P40VLMD	
Power source			1-phase 220-240V 50Hz/1-phase 220-230V 60Hz				
Cooling capacity	*1	kW	2.2	2.8	3.6	4.5	
	*1	BTU/h	7,500	9,600	12,300	15,400	
Heating capacity	*1	kW	2.5	3.2	4.0	5.0	
	*1	BTU/h	8,500	10,900	13,600	17,100	
Power consumption	Cooling	kW	0.072/0.075	0.072/0.075	0.072/0.075	0.081/0.085	
	Heating	kW	0.065/0.069	0.065/0.069	0.065/0.069	0.074/0.079	
Current	Cooling	A	0.36/0.37	0.36/0.37	0.36/0.37	0.40/0.42	
	Heating	A	0.30/0.32	0.30/0.32	0.30/0.32	0.34/0.37	
External finish (Munsell No.)	Unit	Galvanized steel plate					
	Panel	Pure white (6.4Y 8.9/0.4)					
Panel Model			CMP-40VLW-C				
Dimension H x W x D	Unit	mm (in.)	290 x 776 x 634 (11-7/16 x 30-9/16 x 25)				
	Panel	mm (in.)	65 x 1080 x 710 (2-9/16 x 42-9/16 x 28)				
Net weight	Unit	kg (lbs.)	23 (51)		24 (53)		
	Panel	kg (lbs.)	6.5 (15)				
Heat exchanger			Cross fin (Aluminum plate fin and copper tube)				
Fan	Type x Quantity		Turbo fan x 1				
	Airflow rate (Lo-Mid-Hi)	*2	m <sup>3</sup> /min	6.5-8.0-9.5		7.0-8.5-10.5	
			L/s	108-133-158		117-142-175	
			cfm	230-283-335		247-300-371	
External static pressure		Pa	0				
Motor	Type	1-phase induction motor					
	Output	kW	0.015 (at 240V)				
Air filter			PP honeycomb fabric (long life type)				
Refrigerant pipe diameter	Gas (Flare)	mm (in.)	ø12.7 (ø1/2)				
	Liquid (Flare)	mm (in.)	ø6.35 (ø1/4)				
Field drain pipe diameter		mm (in.)	O.D.32 (1-1/4)				
Sound pressure level (Lo-Mid-Hi) *2 *3	220V,	dB (A)	27-30-33			29-33-36	
	240V		28-31-34				
	230V	dB (A)	30-34-37				

Model			PLFY-P50VLMD	PLFY-P63VLMD	PLFY-P80VLMD	PLFY-P100VLMD	
Power source			1-phase 220-240V 50Hz/1-phase 220-230V 60Hz				
Cooling capacity	*1	kW	5.6	7.1	9.0	11.2	
	*1	BTU/h	19,100	24,200	30,700	38,200	
Heating capacity	*1	kW	6.3	8.0	10.0	12.5	
	*1	BTU/h	21,500	27,300	34,100	42,700	
Power consumption	Cooling	kW	0.082/0.086	0.101/0.105	0.147/0.156	0.157/0.186	
	Heating	kW	0.075/0.080	0.094/0.099	0.140/0.150	0.150/0.180	
Current	Cooling	A	0.41/0.43	0.49/0.51	0.72/0.74	0.75/0.88	
	Heating	A	0.35/0.38	0.43/0.46	0.66/0.69	0.69/0.83	
External finish (Munsell No.)	Unit	Galvanized steel plate					
	Panel	Pure white (6.4Y 8.9/0.4)					
Panel Model			CMP-63VLW-C		CMP-100VLW-C		
Dimension H x W x D	Unit	mm (in.)	290 x 946 x 634 (11-7/16 x 37-1/4 x 25)		290 x 1446 x 634 (11-7/16 x 56-15/16 x 25)		
	Panel	mm (in.)	65 x 1250 x 710 (2-9/16 x 49-1/4 x 28)		65 x 1750 x 710 (2-9/16 x 68-15/16 x 28)		
Net weight	Unit	kg (lbs.)	27 (60)	28 (62)	44 (98)	47 (104)	
	Panel	kg (lbs.)	7.5 (17)		12.5 (28)		
Heat exchanger			Cross fin (Aluminum plate fin and copper tube)				
Fan	Type x Quantity		Turbo fan x 1		Turbo fan x 2		
	Airflow rate (P50~P100:Lo-Mid-Hi) (P125:Lo-Mid2-Mid1-Hi)	*2	m <sup>3</sup> /min	9.0-11.0-12.5	11.0-13.0-15.5	15.5-18.5-22.0	17.5-21.0-25.0
			L/s	150-183-208	167-217-258	258-308-367	292-350-417
			cfm	318-388-441	353-459-547	547-653-777	618-742-883
External static pressure		Pa	0				
Motor	Type	1-phase induction motor					
	Output	kW	0.020 (at 240V)		0.020 (at 240V)	0.030 (at 240V)	
Air filter			PP honeycomb fabric (long life type)				
Refrigerant pipe diameter	Gas (Flare)	mm (in.)	ø12.7 (ø1/2)		ø15.88 (ø5/8)		
	Liquid (Flare)	mm (in.)	ø6.35 (ø1/4)		ø9.52 (ø3/8)		
Field drain pipe diameter		mm (in.)	O.D.32 (1-1/4)				
Sound pressure level (Lo-Mid-Hi) *2 *3	220V,	dB (A)	31-34-37		32-37-39		
	240V		32-35-38		33-36-39		
	230V	dB (A)	33-38-40		34-37-40		

### Notes:

\*1 Cooling/Heating capacity indicates the maximum value at operation under the following condition.  
 Cooling : Indoor 27°C(81°F)DB/19°C(66°F)WB, Outdoor 35°C(95°F)DB  
 Heating : Indoor 20°C(68°F)DB, Outdoor 7°C(45°F)DB/6°C(43°F)WB

\*2 Airflow rate/Sound pressure level are in (low-middle-high) or (low-middle2-middle1-high).

\*3 It is measured in anechoic room.

# 1-way airflow cassette type

## PMFY-P VBM

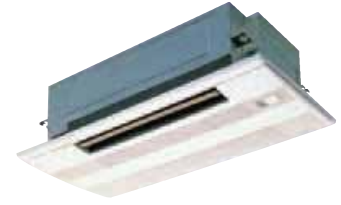

### Specifications

Model			PMFY-P20VBM	PMFY-P25VBM	PMFY-P32VBM	PMFY-P40VBM
Power source			1-phase 220-240V 50Hz/1-phase 220V 60Hz			
Cooling capacity	*1	kW	2.2	2.8	3.6	4.5
	*1	BTU/h	7,500	9,600	12,300	15,400
Heating capacity	*1	kW	2.5	3.2	4.0	5.0
	*1	BTU/h	8,500	10,900	13,600	17,100
Power consumption	Cooling	kW	0.042		0.044	0.054
	Heating	kW	0.042		0.044	0.054
Current	Cooling	A	0.20		0.21	0.26
	Heating	A	0.20		0.21	0.26
External finish (Munsell No.)			White (6.4Y 8.9/0.4)			
Dimension	Unit	mm (in.)	230 x 812 x 395 (9-1/16 x 32 x 15-9/16)			
	Panel	mm (in.)	30 x 1000 x 470 (1-3/16 x 39-3/8 x 18-9/16)			
Net weight	Unit	kg (lbs.)	14 (31)			
	Panel	kg (lbs.)	3 (7)			
Heat exchanger			Cross fin (Aluminum plate fin and copper tube)			
Fan	Type x Quantity		Line flow fan x 1			
	Airflow rate (Lo-Mid2-Mid1-Hi)	*2	m <sup>3</sup> /min	6.5-7.2-8.0-8.7	7.3-8.0-8.6-9.3	7.7-8.7-9.7-10.7
			L/s	108-120-133-145	122-133-143-155	128-145-162-178
			cfm	230-254-283-307	258-283-304-328	272-307-343-378
External static pressure		Pa	0			
Motor	Type		1-phase induction motor			
	Output		0.028			
Air filter			PP Honeycomb fabric			
Refrigerant pipe diameter	Gas (Flare)	mm (in.)	ø12.7 (ø1/2)			
	Liquid (Flare)	mm (in.)	ø6.35 (ø1/4)			
Field drain pipe diameter		mm (in.)	O.D. 26 (1)			
Sound pressure level (Lo-Mid2-Mid1-Hi)*2 *3		dB (A)	27-30-33-35	32-34-36-37	33-35-37-39	

# PMFY-P VFM

### Specifications



Model			PMFY-P50VFM	PMFY-P63VFM	PMFY-P71VFM	PMFY-P80VFM	
Power source			1-phase 220-240V50Hz/ 1-phase 220-230V60Hz				
Cooling capacity	*1	kW	5.6	7.1	8	9	
	*1	BTU/h	19,100	24,200	27,300	30,700	
Heating capacity	*1	kW	6.3	8	9	10	
	*1	BTU/h	21,500	27,300	30,700	34,100	
Power consumption	Cooling	kW	0.06	0.075	0.09	0.13	
	Heating	kW	0.045	0.06	0.075	0.12	
Current	Cooling	A	0.47	0.63	0.74	1.01	
	Heating	A	0.42	0.55	0.62	0.96	
External finish (Munsell No.)			White (6.4Y8.9/0.4)				
Dimension	Unit	mm (in.)	225 x 1112 x 724 (8-7/8 x 43-3/4 x 24-1/2)				
	Panel	mm (in.)	20 x 1340 x 800 (13/16 x 52-3/4 x 31-1/2)				
Net weight	Unit	kg (lbs.)	26 (57)	28 (62)	29 (64)		
	Panel	kg (lbs.)	6.5 (14)				
Heat exchanger			Crossfin (Aluminum plate fin and copper tube)				
Fan	Type x Quantity		Sirocco fan x 2		Sirocco fan x 3		
	Airflow rate (Lo-Mid2-Mid1-Hi)	*2	m <sup>3</sup> /min	11-12-14-16	14-16-17-19	14-16-18-20	12-16-20-24
			L/s	183-200-233-267	233-267-283-317	233-267-300-333	198-269-335-401
			cfm	388-424-494-565	494-565-600-671	494-565-636-706	420-570-710-850
External static			0				
Motor	Type		DC motor				
	Output		0.09		0.095		
Air filter			PP honeycomb fabric				
Refrigerant pipe diameter	Gas (Flare)	mm (in.)	ø12.7 (ø1/2)		ø15.88 (ø5/8)		
	Liquid (Flare)	mm (in.)	ø6.35 (ø1/4)		ø9.52 (ø3/8)		
Field drain pipe diameter		mm (in.)	O.D.32 (1-1/4)				
Sound pressure level (Lo-Mid-Hi)		*2 *3	29-32-35-38	32-35-37-39	32-35-38-41	36-41-46-50	

#### Notes:

- \*1 Cooling/Heating capacity indicates the maximum value at operation under the following condition  
Cooling : Indoor 27°C(81°F)DB/19°C(66°F)WB, Outdoor 35°C(95°F)DB  
Heating : Indoor 20°C(68°F)DB, Outdoor 7°C(45°F)DB/6°C(43°F)WB
- \*2 Airflow rate/Sound pressure level are in (low-middle2-middle1-high).
- \*3 It is measured in anechoic room.

# Low static pressure ceiling concealed type PEFY-P VMS1(L)

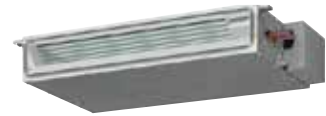

Model			PEFY-P15VMS1(L)	PEFY-P20VMS1(L)	PEFY-P25VMS1(L)	PEFY-P32VMS1(L)	PEFY-P40VMS1(L)	PEFY-P50VMS1(L)	PEFY-P63VMS1(L)	
Power source			1-phase 220-240V 50Hz/1-phase 220-240V 60Hz							
Cooling capacity	*1	kW	1.7	2.2	2.8	3.6	4.5	5.6	7.1	
	*1	BTU/h	5,800	7,500	9,600	12,300	15,400	19,100	24,200	
Heating capacity	*1	kW	1.9	2.5	3.2	4.0	5.0	6.3	8.0	
	*1	BTU/h	6,500	8,500	10,900	13,600	17,100	21,500	27,300	
Power consumption	*3	Cooling kW	0.05 [0.03]	0.05 [0.03]	0.06 [0.04]	0.07 [0.05]	0.07 [0.05]	0.09 [0.07]	0.09 [0.07]	
		Heating kW	0.03 [0.03]	0.03 [0.03]	0.04 [0.04]	0.05 [0.05]	0.05 [0.05]	0.07 [0.07]	0.07 [0.07]	
Current	*3	Cooling A	0.42 [0.31]	0.47 [0.36]	0.50 [0.39]	0.50 [0.39]	0.56 [0.45]	0.67 [0.56]	0.72 [0.61]	
		Heating A	0.31 [0.31]	0.36 [0.36]	0.39 [0.39]	0.39 [0.39]	0.45 [0.45]	0.56 [0.56]	0.61 [0.61]	
External finish			Galvanized							
Dimension H x W x D	mm		200 x 790 x 700				200 x 990 x 700		200 x 1,190 x 700	
	in.		7-7/8 x 31-1/8 x 27-9/16				7-7/8 x 39 x 27-9/16		7-7/8 x 46-7/8 x 27-9/16	
Net weight	*3	kg (lbs.)	19 (42) [18 (40)]			20 (45) [19 (42)]		24 (53) [23 (51)]		28 (62) [27 (60)]
Heat exchanger			Cross fin (Aluminium fin and copper tube)							
Fan	Type x Quantity		Sirocco fan x 2				Sirocco fan x 3		Sirocco fan x 4	
	Airflow rate (Lo-Mid-Hi)	m <sup>3</sup> /min	5-6-7	5.5-6.5-8	5.5-7-9	6-8-10	8-9.5-11	9.5-11-13	12-14-16.5	
		L/s	83-100-117	91-108-133	91-117-150	100-133-167	133-158-183	158-183-217	200-233-275	
External static pressure	Pa	176-212-247	194-229-282	194-247-317	212-282-353	282-335-388	335-388-459	424-494-583		
Motor	Type		DC motor							
	Output	kW	0.096							
Air filter			PP Honeycomb fabric (washable)							
Refrigerant pipe diameter	Gas	mm (in.)	ø12.7 (ø1/2) Brazed						ø15.88 (ø5/8) Brazed	
	Liquid	mm (in.)	ø6.35 (ø1/4) Brazed						ø9.52 (ø3/8) Brazed	
Field drain pipe diameter			O.D. 32 (1-1/4)							
Sound pressure level (Lo-Mid-Hi) (measured in anechoic room)			dB (A)	22-24-28	23-25-29	24-26-30	24-27-32	28-30-33	30-32-35	30-33-36

## Notes:

\*1 Cooling/Heating capacity indicates the maximum value at operation under the following condition.  
Cooling : Indoor : 27°CDB./19°CWB.(81°FDB./66°FWB.) Outdoor : 35°CDB.(95°FDB.)  
Heating : Indoor : 20°CDB.(68°FDB.) Outdoor : 7°CDB./6°CWB.(45°FDB./43°FWB.)  
Pipe length : 7.5m(24-9/16ft) Height difference : 0m(0ft)

\*2 The external static pressure is set to 15 Pa at factory shipment.

\*3 [ ] is in case of PEFY-P15-63VMS1L-E

# Medium static pressure ceiling concealed type

## PEFY-P VMA(L)



Model		PEFY-P20VMA(L)	PEFY-P25VMA(L)	PEFY-P32VMA(L)	PEFY-P40VMA(L)	PEFY-P50VMA(L)	PEFY-P63VMA(L)	
Power source		1-phase 220-230-240V 50/60Hz						
Cooling capacity (Nominal)	*1 kW	2.2	2.8	3.6	4.5	5.6	7.1	
	BTU/h	7,500	9,600	12,300	15,400	19,100	24,200	
Heating capacity (Nominal)	*2 kW	2.5	3.2	4.0	5.0	6.3	8.0	
	BTU/h	8,500	10,900	13,600	17,100	21,500	27,300	
Power consumption	Cooling *3 kW	0.032 [0.030]	0.032 [0.030]	0.044 [0.042]	0.047 [0.045]	0.066 [0.064]	0.087 [0.085]	
	Heating *3 kW	0.030	0.030	0.042	0.045	0.064	0.085	
Current	Cooling *3 A	0.26 - 0.25 - 0.24	0.26 - 0.25 - 0.24	0.36 - 0.34 - 0.33	0.39 - 0.37 - 0.36	0.53 - 0.51 - 0.49	0.69 - 0.66 - 0.63	
	Heating *3 A	0.26 - 0.25 - 0.24	0.26 - 0.25 - 0.24	0.36 - 0.34 - 0.33	0.39 - 0.37 - 0.36	0.53 - 0.51 - 0.49	0.69 - 0.66 - 0.63	
External finish		Galvanized steel plate						
Dimension H x W x D	mm	250 x 700 x 732	250 x 700 x 732	250 x 700 x 732	250 x 900 x 732	250 x 900 x 732	250 x 900 x 732	
	in.	9-7/8 x 27-9/16 x 28-7/8	9-7/8 x 27-9/16 x 28-7/8	9-7/8 x 27-9/16 x 28-7/8	9-7/8 x 35-7/16 x 28-7/8	9-7/8 x 35-7/16 x 28-7/8	9-7/8 x 35-7/16 x 28-7/8	
Net weight	kg (lbs.)	21.5 [21.0]	21.5 [21.0]	21.5 [21.0]	26.0 [25.5]	26.0 [25.5]	27.0 [26.5]	
Heat exchanger		Cross fin (Aluminum fin and copper tube)						
Fan	Type x Quantity	Sirocco fan x 1					Sirocco fan x 2	
	Airflow rate (Lo-Mid-Hi)	m <sup>3</sup> /min	6.0-7.5-8.5	6.0-7.5-8.5	7.5-9.0-10.5	10.0-12.0-14.0	12.0-14.5-17.0	13.5-16.0-19.0
		L/s	100-125-142	100-125-142	125-150-175	167-200-233	200-242-283	225-267-317
		cfm	212-265-300	212-265-300	265-318-371	353-424-494	424-512-600	477-565-671
External static pressure	*4 Pa	35 - <50> - <70> - <100> - <150>						
Motor	Type	DC motor						
	Output	0.085			0.121			
Air filter		PP honeycomb fabric.						
Refrigerant pipe diameter	Liquid (R410A)	mm (in.)	6.35 (1/4) Brazed	6.35 (1/4) Brazed	6.35 (1/4) Brazed	6.35 (1/4) Brazed	6.35 (1/4) Brazed	9.52 (3/8) Brazed
	Gas (R410A)	mm (in.)	12.7 (1/2) Brazed	12.7 (1/2) Brazed	12.7 (1/2) Brazed	12.7 (1/2) Brazed	12.7 (1/2) Brazed	15.88 (5/8) Brazed
Field drain pipe diameter	mm (in.)	O.D.32 (1-1/4)	O.D.32 (1-1/4)	O.D.32 (1-1/4)	O.D.32 (1-1/4)	O.D.32 (1-1/4)	O.D.32 (1-1/4)	
Sound pressure level (measured in anechoic room) (Lo-Mid-Hi)		*3 *5 dB (A)	22.0 - 26.0 - 28.0	22.0 - 26.0 - 28.0	24.0 - 28.0 - 31.0	24.0 - 29.0 - 32.0	25.0 - 32.0 - 35.0	28.0 - 32.0 - 36.0

Model		PEFY-P71VMA(L)	PEFY-P80VMA(L)	PEFY-P100VMA(L)	PEFY-P125VMA(L)	PEFY-P140VMA(L)	
Power source		1-phase 220-230-240V 50/60Hz					
Cooling capacity (Nominal)	*1 kW	8.0	9.0	11.2	14.0	16.0	
	BTU/h	27,300	30,700	38,200	47,800	54,600	
Heating capacity (Nominal)	*2 kW	9.0	10.0	12.5	16.0	18.0	
	BTU/h	30,700	34,100	42,700	54,600	61,400	
Power consumption	Cooling *3 kW	0.080 [0.078]	0.080 [0.078]	0.142 [0.140]	0.199 [0.197]	0.208 [0.206]	
	Heating *3 kW	0.078	0.078	0.140	0.197	0.206	
Current	Cooling *3 A	0.60 - 0.57 - 0.55	0.60 - 0.57 - 0.55	1.01 - 0.97 - 0.93	1.29 - 1.23 - 1.18	1.40 - 1.34 - 1.28	
	Heating *3 A	0.60 - 0.57 - 0.55	0.60 - 0.57 - 0.55	1.01 - 0.97 - 0.93	1.29 - 1.23 - 1.18	1.40 - 1.34 - 1.28	
External finish		Galvanized steel plate					
Dimension H x W x D	mm	250 x 1,100 x 732	250 x 1,100 x 732	250 x 1,400 x 732	250 x 1,400 x 732	250 x 1,600 x 732	
	in.	9-7/8 x 43-5/16 x 28-7/8	9-7/8 x 43-5/16 x 28-7/8	9-7/8 x 55-1/8 x 28-7/8	9-7/8 x 55-1/8 x 28-7/8	9-7/8 x 63 x 28-7/8	
Net weight	kg (lbs.)	30.0 [29.5]	30.0 [29.5]	37.5 [37.0]	38.5 [38.0]	41.5 [41.0]	
Heat exchanger		Cross fin (Aluminum fin and copper tube)					
Fan	Type x Quantity	Sirocco fan x 2					
	Airflow rate (Lo-Mid-Hi)	m <sup>3</sup> /min	14.5-18.0-21.0	14.5-18.0-21.0	23.0-28.0-32.0	28.0-34.0-37.0	29.5-35.5-40.0
		L/s	242-300-350	242-300-350	383-467-533	467-567-617	492-592-667
		cfm	512-636-742	512-636-742	812-989-1,130	989-1,201-1,305	1,042-1,254-1,412
External static pressure	*4 Pa	40 - <50> - <70> - <100> - <150>					
Motor	Type	DC motor					
	Output	0.121			0.244		
Air filter		PP honeycomb fabric.					
Refrigerant pipe diameter	Liquid (R410A)	mm (in.)	9.52 (3/8) Brazed	9.52 (3/8) Brazed	9.52 (3/8) Brazed	9.52 (3/8) Brazed	9.52 (3/8) Brazed
	Gas (R410A)	mm (in.)	15.88 (5/8) Brazed	15.88 (5/8) Brazed	15.88 (5/8) Brazed	15.88 (5/8) Brazed	15.88 (5/8) Brazed
Field drain pipe diameter	mm (in.)	O.D.32 (1-1/4)	O.D.32 (1-1/4)	O.D.32 (1-1/4)	O.D.32 (1-1/4)	O.D.32 (1-1/4)	
Sound pressure level (measured in anechoic room) (Lo-Mid-Hi)		*3 *5 dB (A)	26.0 - 32.0 - 35.0	26.0 - 32.0 - 35.0	31.0 - 36.0 - 39.0	35.0 - 39.0 - 41.0	34.0 - 38.0 - 41.0

### Notes:

\*1 Nominal cooling conditions  
Indoor: 27°CDB/19°CWB (81°FDB/66°FWB), Outdoor: 35°CDB (95°FDB)  
Pipe length: 7.5m (24-9/16 ft.), Level difference: 0m (0 ft.)

\*2 Nominal heating conditions  
Indoor: 20°C(68°F)DB, Outdoor: 7°C(45°F)DB/6°C(43°F)WB  
Pipe length: 7.5m(24-9/16ft.), Level difference: 0m(0ft.)

\*3 The values are measured at the factory setting of external static pressure.

\*4 The factory setting of airflow mode and external static pressure mode is shown without < >.

Refer to "Fan characteristics curves", according to the external static pressure, in DATA BOOK for the usable range of air flow rate.

\*5 Measured in anechoic room with a 1 m air inlet duct and 2 m air outlet duct attached to the unit and 1.5 m below the unit.

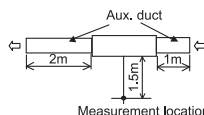

\*Details on foundation work, duct work, insulation work, electrical wiring, power source switch, and other items shall be referred to the Installation Manual.  
\*Due to continuing improvement, above specifications may be subject to change without notice.

# High static pressure ceiling concealed type

## PEFY-P VMHS-E



Model		PEFY-P40VMHS-E	PEFY-P50VMHS-E	PEFY-P63VMHS-E	PEFY-P71VMHS-E	PEFY-P80VMHS-E	PEFY-P100VMHS-E	PEFY-P125VMHS-E	PEFY-P140VMHS-E						
Power source		1-phase 220-230-240 V 50/60 Hz													
Cooling capacity	*1 kW	4.5	5.6	7.1	8.0	9.0	11.2	14.0	16.0						
	*1 BTU/h	15,400	19,100	24,200	27,300	30,700	38,200	47,800	54,600						
Heating capacity	*2 Power input kW	0.055		0.090	0.075	0.090	0.160		0.190						
	*2 Current input (220-230-240 V) A	0.41-0.39-0.38		0.64-0.62-0.59	0.54-0.52-0.50	0.63-0.61-0.58	1.05-1.01-0.96		1.24-1.19-1.14						
	*3 kW	5.0	6.3	8.0	9.0	10.0	12.5	16.0	18.0						
External finish	*3 BTU/h	17,100	21,500	27,300	30,700	34,100	42,700	54,600	61,400						
	*2 Power input kW	0.055		0.090	0.075	0.090	0.160		0.190						
	*2 Current input (220-230-240 V) A	0.41-0.39-0.38		0.64-0.62-0.59	0.54-0.52-0.50	0.63-0.61-0.58	1.05-1.01-0.96		1.24-1.19-1.14						
External dimension H x W x D		mm			Galvanized steel plate			380 x 1,195 x 900							
		in.			380 x 1,030 x 900			380 x 1,195 x 900							
Net weight		kg (lbs.)			15 x 29-3/8 x 35-7/16			15 x 47-1/16 x 35-7/16							
		35 (78)			45 (100)			51 (113)							
Heat exchanger		Cross fin (Aluminum fin and copper tube)													
Fan		Type x Quantity				Sirocco fan x 1				Sirocco fan x 2					
*4 External static press.	Pa					50-<100>-<150>-<200>									
	mmH <sub>2</sub> O					5.1-<10.2>-<15.3>-<20.4>									
Motor Type		DC motor													
Motor output		kW				0.121				0.244					
Air flow rate		(Low-Mid-High)													
		m <sup>3</sup> /min		10.0-12.0-14.0		13.5-16.0-19.0		15.5-18.0-22.0		18.0-21.5-25.0		26.5-32.0-38.0		28.0-34.0-40.0	
		L/s		167-200-233		225-267-317		258-300-367		300-358-417		442-533-633		467-567-667	
		cfm		353-424-494		477-565-671		547-636-777		636-759-883		936-1,130-1,342		989-1,201-1,412	
Sound pressure level (measured in anechoic room)		(Low-Mid-High)													
		*2 dB <A>		20-23-27		24-27-32		24-26-30		25-27-30		27-31-34		27-32-36	
Air filter		Option: Synthetic fiber unwoven cloth filter (long life filter) and filter box are recommended.													
Refrigerant piping diameter	Gas (R410A)	mm (in.)				12.7 (1/2) Brazed				15.88 (5/8) Brazed					
	Liquid (R410A)	mm (in.)				6.35 (1/4) Brazed				9.52 (3/8) Brazed					
Field drain pipe diameter		mm (in.)								O.D.32 (1-1/4)					

Model		PEFY-P200VMHS-E	PEFY-P250VMHS-E
Power source		1-phase 220-240V 50Hz/1-phase 220-240V 60Hz	
Cooling capacity	*5 kW	22.4	28.0
	*5 BTU/h	76,400	95,500
Heating capacity	*5 kW	25.0	31.5
	*5 BTU/h	85,300	107,500
Power consumption	Cooling kW	0.63 *2	
	Heating kW	0.63 *2	
Current	Cooling 220-230-240V A	3.47-3.32-3.18 *2	
	Heating 220-230-240V A	3.47-3.32-3.18 *2	
External finish		Galvanized steel plate	
Dimension H x W x D		mm	
		in.	
		470 x 1,250 x 1,120	
		18-9/16 x 49-1/4 x 44-1/8	
Net weight		kg (lbs.)	
		97 (214)	
Heat exchanger		Cross fin (Aluminum plate fin and copper tube)	
Fan		Type x Quantity	
Airflow rate (Lo-Mid-Hi)	m <sup>3</sup> /min	50.0-61.0-72.0	
	L/s	833-1017-1200	
	cfm	1766-2154-2542	
External static pressure	Pa	<50>-<100>-<150>-<200>-<250> *6	
	mmH <sub>2</sub> O	<5.1>-<10.2>-<15.3>-<20.4>-<25.5> *6	
Motor		Type	
		DC motor	
		Output kW	
		0.87	
Air filter (option)		Synthetic fiber unwoven cloth filter (long life filter) and filter box are recommended.	
Refrigerant pipe diameter	Gas (Brazing)	mm (in.)	
	Liquid (Brazing)	mm (in.)	
		ø19.05 (ø3/4)	
		ø22.2 (ø7/8)	
Field drain pipe diameter		mm (in.)	
		O.D. 32 (1-1/4)	
Sound pressure level		Lo-Mid-Hi	
		dB (A)	
		36-39-43 *7	
		39-42-46 *7	

### Notes:

- \*1 Nominal cooling conditions  
Indoor: 27°C DB/19°C WB. (81°F DB/66°F WB.), Outdoor: 35°C DB. (95°F DB.)  
Pipe length: 7.5 m (24-9/16 ft.), Level difference: 0 m (0 ft.)
- \*2 The values are measured at the factory setting of external static pressure.
- \*3 Nominal heating conditions  
Indoor: 20°C DB. (68°F DB.), Outdoor: 7°C DB/6°C WB. (45°F DB./43°F WB.)  
Pipe length: 7.5 m (24-9/16 ft.), Level difference: 0 m (0 ft.)
- \*4 The factory setting of external static pressure is shown without < >.  
Refer to "Fan characteristics curves", according to the external static pressure, in DATA BOOK for the usable range of air flow rate.

- \*5 Cooling/heating capacity indicates the maximum value at operation under the following condition.  
Cooling Indoor : 27°C(81°F)DB/19°C(66°F)WB, Outdoor : 35°C(95°F)DB  
Heating Indoor : 20°C(68°F)DB, Outdoor : 7°C(45°F)DB/6°C(43°F)WB
- \*6 The external static pressure is set to 220Pa (at 380V) /260Pa (at 400, 415V) at factory shipment.
- \*7 The value are that at 415V.
- \*8 It is measured in anechoic room.
- \*9 The rated external static pressure is shown without < >.  
The factory setting is the rated value.
- \*10 It is measured at the rated external static pressure in anechoic room.

# Fresh air intake ceiling concealed type

## PEFY-P VMHS-E-F



Model		PEFY-P125VMHS-E-F	PEFY-P200VMHS-E-F	PEFY-P250VMHS-E-F *6				
Power source		1-phase 220-230-240 V 50/60 Hz	1-phase 220-230-240 V 50/60 Hz	1-phase 220-230-240 V 50/60 Hz				
Cooling capacity (Nominal)	*1 kW	14.0	22.4	28.0				
	*1 BTU/h	47,800	76,400	95,500				
	*2 Power input kW	0.220	0.260	0.350				
	*2 Current input (220 V) A	1.43	1.66	2.16				
Temp. range of cooling		17°CDB./15.5°CWB. ~ 43°CDB./35°CWB. * Thermo-off (FAN-mode) automatically starts if the outdoor temperature is lower than 17°CDB.	17°CDB./15.5°CWB. ~ 43°CDB./35°CWB. * Thermo-off (FAN-mode) automatically starts if the outdoor temperature is lower than 17°CDB.	17°CDB./15.5°CWB. ~ 43°CDB./35°CWB. * Thermo-off (FAN-mode) automatically starts if the outdoor temperature is lower than 17°CDB.				
Heating capacity (Nominal)	*3 kW	8.9	13.9	17.4				
	*3 BTU/h	30,400	47,400	59,400				
	*2 Power input kW	0.230	0.270	0.360				
	*2 Current input (220 V) A	1.52	1.85	2.38				
Temp. range of heating		-10°CDB. ~ 20°CDB. * Thermo-off (FAN-mode) automatically starts if the outdoor temperature is higher than 20°CDB.	-10°CDB. ~ 20°CDB. * Thermo-off (FAN-mode) automatically starts if the outdoor temperature is higher than 20°CDB.	-10°CDB. ~ 20°CDB. * Thermo-off (FAN-mode) automatically starts if the outdoor temperature is higher than 20°CDB.				
External finish		Galvanized	Galvanized	Galvanized				
External dimension HxWxD	mm	380 x 1,195 x 900	470 x 1,250 x 1,120	470 x 1,250 x 1,120				
	in.	15 x 47-1/16 x 35-7/16	18-9/16 x 49-1/4 x 44-1/8	18-9/16 x 49-1/4 x 44-1/8				
Net weight		49 (109)	78 (172)	81 (179)				
Heat exchanger		Cross fin (Aluminum fin and copper tube)	Cross fin (Aluminum fin and copper tube)	Cross fin (Aluminum fin and copper tube)				
FAN		Sirocco fan x 1	Sirocco fan x 2	Sirocco fan x 2				
*4, 5	Type x Quantity							
	External static press. Pa	<100> - <150> - 200 - <250>	<100> - <150> - 200 - <250>	<100> - <150> - 200 - <250>				
	mmH <sub>2</sub> O	<10.2> - <15.3> - 20.4 - <25.5>	<10.2> - <15.3> - 20.4 - <25.5>	<10.2> - <15.3> - 20.4 - <25.5>				
	Motor Type	DC motor						
	Motor output kW	0.244	0.375	0.375				
	Driving mechanism	Direct-driven by motor						
*4, 5	Air flow rate (Low-Mid-High)	Normal-airflow rate mode	<High-airflow rate mode>	Normal-airflow rate mode	<High-airflow rate mode>	Normal-airflow rate mode	<High-airflow rate mode>	
		m <sup>3</sup> /min	14.0 - 15.5 - 18.0	15.5 - 18.0 - 20.0	22.5 - 25.0 - 28.0	25.0 - 28.0 - 32.0	28.0 - 31.0 - 35.0	31.0 - 35.0 - 40.0
		L/s	233 - 258 - 300	258 - 300 - 333	375 - 417 - 467	417 - 467 - 533	467 - 517 - 583	517 - 583 - 667
		cfm	494 - 547 - 636	547 - 636 - 706	794 - 883 - 989	883 - 989 - 1,130	989 - 1,095 - 1,236	1,095 - 1,236 - 1,412
Sound pressure level (measured in anechoic room) (Low-Mid-High) *2		Normal-airflow rate mode	<High-airflow rate mode>	Normal-airflow rate mode	<High-airflow rate mode>	Normal-airflow rate mode	<High-airflow rate mode>	
dB <A>		34-37-41	36-40-42	35-38-41	36-39-42	38-40-44	38-41-45	
Air filter		Option: Synthetic fiber unwoven cloth filter (long life filter).						
Refrigerant piping diameter	Liquid (R410A)	9.52 (3/8) Brazed	9.52 (3/8) Brazed	9.52 (3/8) Brazed	9.52 (3/8) Brazed	9.52 (3/8) Brazed	9.52 (3/8) Brazed	
	Gas (R410A)	15.88 (5/8) Brazed	15.88 (5/8) Brazed	19.05 (3/4) Brazed	19.05 (3/4) Brazed	22.22 (7/8) Brazed	22.22 (7/8) Brazed	
Field drain pipe size		O.D.32 (1-1/4)						
Optional parts	Drain pump kit	PAC-DRP10DP-E2	PAC-KE06DM-F	PAC-KE06DM-F	PAC-KE06DM-F	PAC-KE06DM-F	PAC-KE06DM-F	
	Long life filter	PAC-KE89LAF	PAC-KE85LAF	PAC-KE85LAF	PAC-KE85LAF	PAC-KE85LAF	PAC-KE85LAF	
	Filter box	PAC-KE140TB-F	PAC-KE250TB-F	PAC-KE250TB-F	PAC-KE250TB-F	PAC-KE250TB-F	PAC-KE250TB-F	

### Notes:

- \*1 Cooling capacity indicates the maximum value at operation under the following condition, Cooling: Indoor 33°CDB/28°CWB, Outdoor 33°CDB. The set temperature of the remote controller is 18°C.
- \*2 The value are measured at the factory setting of airflow mode and external static pressure.
- \*3 Heating capacity indicates the maximum value at operation under the following condition, Heating: Indoor 0°CDB/-2.9°CWB, Outdoor 0°CDB/-2.9°CWB. The set temperature of the remote controller is 25°C.
- \*4 The factory setting of airflow mode and external static pressure mode is shown without <>. Refer to "Fan characteristics curves", according to the external static pressure, in DATA BOOK for the usable range of air flow rate.
- \*5 If the air flow rate is over the usable range, dew drop can be caused from the air outlet and the air flow rate is changed automatically because of the output down by the fan motor control. If the air flow rate is less than the usable range, condensation from the unit surface can be caused.
- \*6 Regarding P250VMHS-E-F, the middle notch air flow rate is different from the spec value when the external static pressure setting is set to 100Pa. See "Fan characteristics curves" in DATA BOOK for the details.
- The combination of fresh air intake type indoor units with other types of indoor units to handle internal thermal load which may cause the conflict of operation mode. It is not recommended when fresh air intake type indoor unit is connected to the Y or WY series.
- Depending on the air conditioning load, outside temperature, and due to the activation of protection functions, the desired preset temperature may not always be achieved and the discharge temperature may swing. Note that untreated outside air may be delivered directly into the room upon the activation of protection functions.
- Fresh air intake type indoor units cannot be connected to PUMY series, except for PUMY-SP125/140V(Y)KM2, PUMY-CP125/140V/KM2, PUMY-CP125/140/200/225YKM2, PUMY-P200/225YKM3, PUMY-(C)P250/300YBM2. Fresh air intake type indoor unit and PUMY have to be one to one connection. Fresh air intake type unit cannot be connected to an outdoor unit together with PWFY series.
- The maximum connectable indoor units to 1 outdoor unit are 110% (100% in case of heating below -5°C).
- When fresh air intake type indoor units connect to an outdoor unit together with other types of indoor unit, the total capacity of fresh air intake type indoor units needs to be 30% or less of the connected outdoor unit capacity.
- The AUTO mode on the local remote controller is available only when fresh air intake type indoor unit is connected to the R2 or WR2 series of outdoor unit.
- The system changeover function is available only when all the connected indoor units are fresh air intake type indoor units.
- The fan temporary stops during defrost.
- The cooling and heating capacities are the maximum capacities that were obtained by operating in the above air conditions and with a refrigerant pipe of about 7.5 m and a level difference of 0 m.
- The actual capacity characteristics vary with the combination of indoor and outdoor units. See the technical information in DATA BOOK for the details.
- Thermo off (Fan) operation automatically starts either when temperature is lower than 17°CDB in cooling mode or when the temperature exceeds 20°CDB in heating mode.
- Dry mode is not available.
- When this unit is used as sole A/C system, be careful about the dew in air outlet grilles in cooling mode.
- Un-conditioned outdoor air such as humid air or cold air blows to the indoor during thermo off operation. Please be careful when positioning indoor unit air outlet grilles, ie take the necessary precautions for cold air, and also insulate rooms for dew condensation prevention as required.
- Air filter must be installed in the air intake side. The filter should be attached where easy maintenance is possible in case of usage of field supply filters.

# Ceiling suspended exposed type

## PCFY-P VKM



Model		PCFY-P40VKM	PCFY-P63VKM	PCFY-P100VKM	PCFY-P125VKM
Power source		1-phase 220-240V 50Hz/1-phase 220V 60Hz			
Cooling capacity	*1 kW	4.5	7.1	11.2	14.0
	*1 BTU/h	15,400	24,200	38,200	47,800
Heating capacity	*1 kW	5.0	8.0	12.5	16.0
	*1 BTU/h	17,100	27,300	42,700	54,600
Power consumption	Cooling kW	0.04	0.05	0.09	0.11
	Heating kW	0.04	0.05	0.09	0.11
Current	Cooling A	0.28	0.33	0.65	0.76
	Heating A	0.28	0.33	0.65	0.76
External finish (Munsell No.)		6.4Y 8.9/ 0.4			
Dimension H x W x D		mm	230 x 960 x 680	230 x 1,280 x 680	230 x 1,600 x 680
		in.	9-1/16 x 37-13/16 x 26-3/4	9-1/16 x 50-3/8 x 26-3/4	9-1/16 x 63 x 26-3/4
Net weight		kg (lbs.)	24 (53)	32 (71)	36 (79)
Heat exchanger		Cross fin (Aluminum fin and copper tube)			
Fan		Sirocco fan x 2		Sirocco fan x 3	
Airflow rate (Lo-Mid2-Mid1-Hi)	Type x Quantity	Sirocco fan x 2		Sirocco fan x 3	
	*2 m <sup>3</sup> /min	10-11-12-13		14-15-16-18	
	L/s	167-183-200-217		233-250-267-300	
	cfm	353-388-424-459		494-530-565-636	
External static pressure		Pa			
Motor		DC motor			
Output		kW		0.160	
Air filter		PP Honeycomb (long life)			
Refrigerant pipe diameter	Gas (Flare)	mm (in.)	ø12.7 (ø1/2)	ø15.88 (ø5/8)	ø15.88 (ø5/8)
	Liquid (Flare)	mm (in.)	ø6.35 (ø1/4)	ø9.52 (ø3/8)	
Field drain pipe diameter		mm (in.)	O.D. 26 (1)		
Sound pressure level (Lo-Mid2-Mid1-Hi)		*2 *3 dB (A)	29-32-34-36	31-33-35-37	36-38-41-43

### Notes:

\*1 Cooling/Heating capacity indicates the maximum value at operation under the following condition.

Cooling Indoor : 27°C(80.6°F)DB/19°C(66.2°F)WB, Outdoor 35°C(95°F)DB

Heating Indoor : 20°C(68°F)DB, Outdoor 7°C(44.6°F)DB/6°C(42.8°F)WB

\*2 Airflow rate/Sound pressure level are shown in (low-middle 2-middle 1-high).

\*3 It is measured in anechoic room.

# Wall mounted type PKFY-P VLM



Model		PKFY-P15VLM	PKFY-P20VLM	PKFY-P25VLM	PKFY-P32VLM	PKFY-P40VLM	PKFY-P50VLM	
Power source		1-phase 220/230/240V 50Hz, 220/230V 60Hz						
Cooling capacity	*1 kW	1.7	2.2	2.8	3.6	4.5	5.6	
	*1 BTU/h	5,800	7,500	9,600	12,300	15,400	19,100	
Heating capacity	*1 kW	1.9	2.5	3.2	4.0	5.0	6.3	
	*1 BTU/h	6,500	8,500	10,900	13,600	17,100	21,500	
Power consumption	Cooling*4 kW	0.02	0.02	0.03	0.05	0.05	0.05	
	Heating kW	0.01	0.01	0.02	0.04	0.04	0.04	
Current	Cooling*4 A	0.2	0.2	0.25	0.45	0.45	0.45	
	Heating A	0.15	0.15	0.2	0.4	0.4	0.4	
External finish (Munsell No.)		White (0.7PB 9.2/0.4)						
Dimension H x W x D		299 x 773 x 237 (11-25/32 x 30-7/16 x 9-11/32)				299 x 898 x 237 (11-25/32 x 35-3/8 x 9-11/32)		
Net weight		11 (25)				13 (29)		
Heat exchanger		Cross-fin (Aluminum fin and copper tube)						
Fan	Type x Quantity		Line flow fan x 1					
	Airflow rate (Lo-Mid2-Mid1-Hi)	*2 m <sup>3</sup> /min	4.0 - 4.4 - 4.8 - 5.3	4.0 - 4.6 - 5.2 - 5.9	4.0 - 4.6 - 5.4 - 6.7	4.3 - 5.9 - 8.0 - 10.4	6.3 - 7.7 - 9.5 - 11.5	6.8 - 8.3 - 10.2 - 12.4
		L/s	67 - 73 - 80 - 88	67 - 77 - 87 - 98	67 - 77 - 90 - 112	72 - 98 - 133 - 173	105 - 128 - 158 - 192	113 - 138 - 170 - 207
		cfm	141 - 155 - 169 - 187	141 - 162 - 184 - 208	141 - 162 - 191 - 237	152 - 208 - 282 - 367	222 - 272 - 335 - 406	240 - 293 - 360 - 438
External static pressure	Pa	0						
Motor	Type	DC motor						
	Output	0.030						
Air filter		PP honeycomb						
Refrigerant pipe diameter	Gas (Flare)	φ12.7 (φ1/2)						
	Liquid (Flare)	φ6.35 (φ1/4)						
Field drain pipe diameter		I.D. 16 (5/8)						
Sound pressure level (Lo-Mid2-Mid1-Hi)		*2 *3 dB (A)	22-26-28-30	22-27-30-33	22-27-31-35	24-33-41-48	29-35-40-44	31-36-41-46

## Notes:

- \*1 Cooling/Heating capacity indicates the maximum value at operation under the following condition.  
Cooling Indoor : 27°C DB/19°C WB, Outdoor 35°C DB  
Heating Indoor : 20°C DB, Outdoor 7°C DB/6°C WB
- \*2 Airflow rate/Sound pressure level are in (low-middle2-middle1-high).
- \*3 It is measured in anechoic room.
- \*4 Electrical characteristic of cooling are included optional drain-pump.

# Wall mounted type PKFY-P VKM



Model		PKFY-P63VKM	PKFY-P100VKM	
Power source		1-phase 220-230-240V 50Hz/1-phase 220V 60Hz		
Cooling capacity	*1 kW	7.1	11.2	
	*1 BTU/h	24,200	38,200	
Heating capacity	*1 kW	8.0	12.5	
	*1 BTU/h	27,300	42,600	
Power consumption	Cooling*4 kW	0.05	0.08	
	Heating kW	0.04	0.07	
Current	Cooling*4 A	0.37	0.58	
	Heating A	0.30	0.51	
External finish (Munsell No.)		Plastic (1.0Y 9.2/0.2)		
Dimension H x W x D		365 x 1,170 x 295 (14-3/8 x 46-1/16 x 11-5/8)		
Net weight		21 (46)		
Heat exchanger		Cross fin (Aluminum fin and copper tube)		
Fan	Type x Quantity		Line flow fan x 1	
	Airflow rate (Lo-Hi)	*2 m <sup>3</sup> /min	16-20	
		L/s	267-333	
		cfm	565-706	
External static pressure	Pa	706-918		
Motor	Type	DC motor		
	Output	0.056		
Air filter		PP Honeycomb		
Refrigerant pipe diameter	Gas (Flare)	φ15.88 (ø5/8)		
	Liquid (Flare)	φ9.52 (ø3/8)		
Field drain pipe diameter		I.D. 16 (5/8)		
Sound pressure level (Lo-Hi)		*2 *3 dB (A)	39-45	41-49

## Notes:

- \*1 Cooling/heating capacity indicates the maximum value at operation under the following condition.  
Cooling Indoor : 27°C(81°F)DB/19°C(66°F)WB, Outdoor : 35°C(95°F)DB  
Heating Indoor : 20°C(68°F)DB, Outdoor : 7°C(45°F)DB/6°C(43°F)WB
- \*2 Airflow rate/Sound pressure level are in (low-high).
- \*3 It is measured in anechoic room.
- \*4 Electrical characteristic of cooling are included optional drain-pump.

# Floor standing exposed type

## PFFY-P VKM



Model		PFFY-P20VKM	PFFY-P25VKM	PFFY-P32VKM	PFFY-P40VKM	
Power source		1-phase 220-240V 50Hz				
Cooling capacity	*1 kW	2.2	2.8	3.6	4.5	
	*1 BTU/h	7,500	9,600	12,300	15,400	
Heating capacity	*1 kW	2.5	3.2	4.0	5.0	
	*1 BTU/h	8,500	10,900	13,600	17,100	
Power consumption	Cooling kW	0.025	0.025	0.025	0.028	
	Heating kW	0.025	0.025	0.025	0.028	
Current	Cooling A	0.20	0.20	0.20	0.24	
	Heating A	0.20	0.20	0.20	0.24	
External finish		Plastic (Pure white)				
Dimension H x W x D		mm	600 x 700 x 200			
		in.	23-5/8 x 27-9/16 x 7-7/8			
Net weight		kg (lbs.)	15 (34)			
Heat exchanger		Cross fin (Aluminium plate fin and copper tube)				
Fan		Line flow fan x 2				
Airflow rate (Lo-Mid-Hi-SHi)	*2 m <sup>3</sup> /min	5.9-6.8-7.6-8.7	6.1-7.0-8.0-9.1	6.1-7.0-8.0-9.1	8.0-9.0-9.5-10.7	
	External static pressure	Pa				
Motor		DC motor				
Output		kW				
Air filter		PP honeycomb fabric (Catechin Filter)				
Refrigerant pipe diameter	Gas (Flare)	mm (in.)				
	Liquid (Flare)	mm (in.)				
Field drain pipe diameter		mm (in.)				
Sound pressure level (Lo-Mid-Hi-SHi)		*2 dB (A)	27-31-34-37	28-32-35-38	28-32-35-38	35-38-42-44

### Notes:

- \*1 Cooling/heating capacity indicates the maximum value at operation under the following condition.  
 Cooling Indoor : 27°C(81°F)DB/19°C(66°F)WB, Outdoor : 35°C(95°F)DB  
 Heating Indoor : 20°C(68°F)DB, Outdoor : 7°C(45°F)DB/6°C(43°F)WB
- \*2 Airflow rate/Sound pressure level are in (low-middle-high-shigh).
- \*3 It is measured in anechoic room.

# Floor standing exposed type

## PFFY-P VLEM



Model		PFFY-P20VLEM	PFFY-P25VLEM	PFFY-P32VLEM	PFFY-P40VLEM	PFFY-P50VLEM	PFFY-P63VLEM	
Power source		1-phase 220-240V 50Hz/1-phase 208-230V 60Hz						
Cooling capacity	*1 kW	2.2	2.8	3.6	4.5	5.6	7.1	
	*1 BTU/h	7,500	9,600	12,300	15,400	19,100	24,200	
Heating capacity	*1 kW	2.5	3.2	4.0	5.0	6.3	8.0	
	*1 BTU/h	8,500	10,900	13,600	17,100	21,500	27,300	
Power consumption	Cooling kW	0.04/0.06		0.06/0.07	0.065/0.075	0.085/0.09	0.1/0.11	
	Heating kW	0.04/0.06		0.06/0.07	0.065/0.075	0.085/0.09	0.1/0.11	
Current	Cooling A	0.19/0.25		0.29/0.30	0.32/0.33	0.40/0.41	0.46/0.47	
	Heating A	0.19/0.25		0.29/0.30	0.32/0.33	0.40/0.41	0.46/0.47	
External finish (Munsell No.)		Acrylic paint (5Y 8/1)						
Dimension H x W x D		mm	630 x 1,050 x 220		630 x 1,170 x 220		630 x 1,410 x 220	
		in.	24-13/16 x 41-3/8 x 8-11/16		24-13/16 x 46-1/8 x 8-11/16		24-13/16 x 55-9/16 x 8-11/16	
Net weight		kg (lbs.)	28 (62)	30 (67)	32 (71)	36 (80)	37 (82)	
Heat exchanger		Cross fin (Aluminum plate fin and copper tube)						
Fan		Sirocco fan x 1			Sirocco fan x 2			
Airflow rate (Lo-Hi)	*2 m <sup>3</sup> /min	5.5-6.5		7.0-9.0	9.0-11.0	12.0-14.0	12.0-15.5	
	L/s	92-108		117-150	150-183	200-233	200-258	
External static pressure	cfm	194-230		247-318	318-388	424-494	424-547	
	Pa	0						
Motor		1-phase induction motor						
Output		kW		0.015	0.018	0.030	0.035	0.050
Air filter		PP Honeycomb fabric (washable)						
Refrigerant pipe diameter	Gas (Flare)	mm (in.)					ø15.88 (ø5/8)	
	Liquid (Flare)	mm (in.)					ø9.52 (ø3/8)	
Field drain pipe diameter		mm (in.)						
Sound pressure level (Lo-Hi)		*2 *3 *4 dB (A)	34-40	35-40	38-43	40-46		

### Notes:

- \*1 Cooling/Heating capacity indicates the maximum value at operation under the following condition.  
 Cooling Indoor : 27°C(81°F)DB/19°C(66°F)WB, Outdoor 35°C(95°F)DB  
 Heating Indoor : 20°C(68°F)DB, Outdoor 7°C(45°F)DB/6°C(43°F)WB
- \*2 Air flow rate/Sound pressure level are in (Low-High)
- \*3 Measured point : 1m x 1m, Power supply : AC240V/50Hz  
 · 1dB(A) lower at AC230V/50Hz  
 · 2dB(A) lower at AC220V/50Hz  
 · 3dB(A) lower at 1.5m x 1.5m point
- \*4 It is measured in anechoic room.

# Floor standing concealed type

## PFFY-P VCM



Model		PFFY-P20VCM	PFFY-P25VCM	PFFY-P32VCM
Power source		1-phase 220-230-240 V 50/60 Hz		
Cooling capacity (Nominal)	*1 kW	2.2	2.8	3.6
	*1 BTU/h	7,500	9,600	12,300
	*2 Power input kW	0.022	0.026	0.031
	*2 Current input A	0.25	0.30	0.34
Heating capacity (Nominal)	*3 kW	2.5	3.2	4.0
	*3 BTU/h	8,500	10,900	13,600
	*2 Power input kW	0.022	0.026	0.031
	*2 Current input A	0.25	0.30	0.34
External finish		Galvanized steel plate		
External dimension	*4 mm	615 (690) x 700 x 200	615 (690) x 700 x 200	615 (690) x 700 x 200
H x W x D	in.	24-1/4 (27-3/16) x 27-9/16 x 7-7/8	24-1/4 (27-3/16) x 27-9/16 x 7-7/8	24-1/4 (27-3/16) x 27-9/16 x 7-7/8
Net weight	kg (lbs)	18 (40)	18 (40)	18.5 (42)
Heat exchanger		Cross fin (Aluminum fin and copper tube)		
FAN		Sirocco fan x 2		
*5	Type x Quantity	Sirocco fan x 2		
	External static press.	Pa	<0> - 10 - <40> - <60>	<0> - 10 - <40> - <60>
		mmH <sub>2</sub> O	<0.0> - 1.0 - <4.1> - <6.1>	<0.0> - 1.0 - <4.1> - <6.1>
	Motor Type		DC motor	DC motor
	Motor output	kW	0.096	0.096
Driving mechanism		Direct-driven by motor		
Air flow rate		(Low-Mid-High)		
	m <sup>3</sup> /min	5.0 - 6.0 - 7.0	5.5 - 6.5 - 8.0	5.5 - 7.0 - 8.5
	L/s	83 - 100 - 117	92 - 108 - 133	92 - 117 - 142
	cfm	177 - 212 - 247	194 - 230 - 282	194 - 247 - 300
Sound pressure level (measured in anechoic room)		(Low-Mid-High)		
	*2 dB<A>	21-23-26	22-25-29	23-26-30
Air filter		PP honeycomb fabric.		
Refrigerant	Liquid (410A)	6.35 (1/4)Braze	6.35 (1/4)Braze	6.35 (1/4)Braze
piping diameter	Gas (410A)	12.7 (1/2)Braze	12.7 (1/2)Braze	12.7 (1/2)Braze
Field drain pipe size	mm (in.)	O.D.32 (1-1/4)	O.D.32 (1-1/4)	O.D.32 (1-1/4)

Model		PFFY-P40VCM	PFFY-P50VCM	PFFY-P63VCM
Power source		1-phase 220-230-240 V 50/60 Hz		
Cooling capacity (Nominal)	*1 kW	4.5	5.6	7.1
	*1 BTU/h	15,400	19,100	24,200
	*2 Power input kW	0.038	0.052	0.058
	*2 Current input A	0.38	0.50	0.49
Heating capacity (Nominal)	*3 kW	5.0	6.3	8.0
	*3 BTU/h	17,100	21,500	27,300
	*2 Power input kW	0.038	0.052	0.058
	*2 Current input A	0.38	0.50	0.49
External finish		Galvanized steel plate		
External dimension	*4 mm	615 (690) x 900 x 200	615 (690) x 900 x 200	615 (690) x 1,100 x 200
H x W x D	in.	24-1/4 (27-3/16) x 35-7/16 x 7-7/8	24-1/4 (27-3/16) x 35-7/16 x 7-7/8	24-1/4 (27-3/16) x 43-5/16 x 7-7/8
Net weight	kg (lbs)	22.5 (51)	22.5 (51)	25.5 (58)
Heat exchanger		Cross fin (Aluminum fin and copper tube)		
FAN		Sirocco fan x 3		
*5	Type x Quantity	Sirocco fan x 3		
	External static press.	Pa	<0> - 10 - <40> - <60>	<0> - 10 - <40> - <60>
		mmH <sub>2</sub> O	<0.0> - 1.0 - <4.1> - <6.1>	<0.0> - 1.0 - <4.1> - <6.1>
	Motor Type		DC motor	DC motor
	Motor output	kW	0.096	0.096
Driving mechanism		Direct-driven by motor		
Air flow rate		(Low-Mid-High)		
	m <sup>3</sup> /min	8.0 - 9.5 - 11.0	10.0 - 11.5 - 13.5	12.0 - 14.0 - 16.5
	L/s	133 - 158 - 183	167 - 192 - 225	200 - 233 - 275
	cfm	282 - 335 - 388	353 - 406 - 477	424 - 494 - 583
Sound pressure level (measured in anechoic room)		(Low-Mid-High)		
	*2 dB<A>	25-27-30	28-31-34	28-32-35
Air filter		PP honeycomb fabric.		
Refrigerant	Liquid (410A)	6.35 (1/4)Braze	6.35 (1/4)Braze	9.52 (3/8)Braze
piping diameter	Gas (410A)	12.7 (1/2)Braze	12.7 (1/2)Braze	15.88 (5/8)Braze
Field drain pipe size	mm (in.)	O.D.32 (1-1/4)	O.D.32 (1-1/4)	O.D.32 (1-1/4)

### Notes:

- \*1. Nominal cooling conditions  
Indoor: 27°C D.B./19°C W.B. (81°F D.B./66°F W.B.), Outdoor: 35°C D.B. (95°F D.B.)  
Pipe length: 7.5 m (24-9/16 ft.), Level difference: 0 m (0 ft.)
- \*2. The values are measured at the factory setting of external static pressure.
- \*3. Nominal heating conditions  
Indoor: 20°C D.B. (68°F D.B.), Outdoor: 7°C D.B./6°C W.B. (45°F D.B./43°F W.B.)  
Pipe length: 7.5 m (24-9/16 ft.), Level difference: 0 m (0 ft.)
- \*4. The values in ( ) show the height of unit with leg.
- \*5. The factory setting of external static pressure is shown without < >.  
Refer to "Fan characteristics curves", according to the external static pressure, in DATA BOOK for the usable range of air flow rate.
- \*Details on foundation work, duct work, insulation work, electrical wiring, power source switch, and other items shall be referred to the Installation Manual.
- \*Due to continuing improvement, above specifications may be subject to change without notice.

# Floor standing exposed type

## PFFY-P YM(H)



Model		PFFY-P200YM	PFFY-P250YM	PFFY-P200YMH	PFFY-P250YMH	PFFY-P400YM	PFFY-P500YM	
Power source		3-phase 4-wire 380-400-415 V 50/60 Hz						
Cooling capacity (Nominal)	*1 kW	22.4	28.0	22.4	28.0	45.0	56.0	
	*1 BTU/h	76,400	95,500	76,400	95,500	153,500	191,100	
	*2 Power input	kW	0.490/0.680	1.05/1.26	1.00/1.41	1.31/1.41	2.86/3.79	3.94/5.30
	*2 Current input (380-400-415 V)	A	0.97-0.98-0.99/ 1.24-1.23-1.22	1.74-1.83-1.88/ 2.06-2.05-2.04	1.82-1.85-1.87/ 2.37-2.37-2.37	2.14-2.18-2.20/ 2.18-2.18-2.18	5.23-5.25-5.33/ 6.16-6.18-6.26	7.66-7.68-7.76/ 8.49-8.51-8.58
Heating capacity (Nominal)	*3 kW	25.0	31.5	25.0	31.5	50.0	63.0	
	*3 BTU/h	85,300	107,500	85,300	107,500	170,600	215,000	
	*2 Power input	kW	0.490/0.680	1.05/1.26	1.00/1.41	1.31/1.41	2.86/3.79	3.94/5.30
	*2 Current input (380-400-415 V)	A	0.97-0.98-0.99/ 1.24-1.23-1.22	1.74-1.83-1.88/ 2.06-2.05-2.04	1.82-1.85-1.87/ 2.37-2.37-2.37	2.14-2.18-2.20/ 2.18-2.18-2.18	5.23-5.25-5.33/ 6.16-6.18-6.26	7.66-7.68-7.76/ 8.49-8.51-8.58
External finish		Galvanized steel plate (with polyester coating) <MUNSELL 3.0Y 7.8/1.1 or similar>						
External dimension H x W x D	mm	1,665 x 1,200 x 500	1,665 x 1,200 x 500	1,465 x 1,200 x 500	1,465 x 1,200 x 500	1,800 x 1,860 x 650	1,800 x 1,860 x 650	
	in.	65-9/16 x 47-1/4 x 19-11/16	65-9/16 x 47-1/4 x 19-11/16	57-11/16 x 47-1/4 x 19-11/16	57-11/16 x 47-1/4 x 19-11/16	70-7/8 x 73-1/4 x 25-5/8	70-7/8 x 73-1/4 x 25-5/8	
Net weight	kg (lbs)	157 (347)	158 (349)	138 (305)	139 (307)	310 (684)	362 (799)	
Heat exchanger		Cross fin (Aluminum fin and copper tube)						
Fan	Type x Quantity		Sirocco fan x 2	Sirocco fan x 2	Sirocco fan x 2	Sirocco fan x 2	Sirocco fan x 2	Sirocco fan x 2
	External static press. (380 V)	Pa	<0>	<0>	<180>/<200>	<180>/<210>	<210>/<390>	<290>/<510>
		mmH <sub>2</sub> O	<0.0>	<0.0>	<18.4>/<20.4>	<18.4>/<21.4>	<21.4>/<39.8>	<29.6>/<52.0>
	Motor Type		3-phase induction motor					
	Motor output	kW	0.400	0.500	0.770	0.770	3.700	5.500
	Driving mechanism		Direct-driven by motor				Belt driving	
	Air flow rate		(High-Low)			(High)		
		m <sup>3</sup> /min	65.0-59.0/69.0-60.0	77.0-56.0/72.0-50.0	65.0	72.0	150.0	200.0
		L/s	1,083-983/1,150-1,000	1,283-933/1,200-833	1,083	1,200	2,500	3,333
		cfm	2,295-2,083/2,436-2,119	2,719-1,977/2,542-1,766	2,295	2,542	5,297	7,062
Sound pressure level (measured in anechoic room) (380 V)		(High-Low)			(High)			
	*2 dB (A)	58-56/60-56	63-60/62-60	58/60	60/61	68/69	69/69	
Air filter		PP honeycomb fabric.						
Refrigerant piping diameter	Liquid (R410A)	mm (in.)	9.52 (3/8) Brazed	9.52 (3/8) Brazed	9.52 (3/8) Brazed	9.52 (3/8) Brazed	12.7 (1/2) Brazed	15.88 (5/8) Brazed
	Gas (R410A)	mm (in.)	22.22 (7/8) Brazed	22.22 (7/8) Brazed	22.22 (7/8) Brazed	22.22 (7/8) Brazed	28.58 (1-1/8) Brazed	28.58 (1-1/8) Brazed
Field drain pipe size		in. Rc 1						

### Notes:

\*1 Nominal cooling conditions

Indoor: 27°C D.B./19°C W.B. (81°F D.B./66°F W.B.), Outdoor: 35°C D.B. (95°F D.B.)  
Pipe length: 7.5 m (24-9/16 ft.), Level difference: 0 m (0 ft.)

\*2 The values are measured at the factory setting of external static pressure.

\*3 Nominal heating conditions

Indoor: 20°C D.B. (68°F D.B.), Outdoor: 7°C D.B./6°C W.B. (45°F D.B./43°F W.B.)  
Pipe length: 7.5 m (24-9/16 ft.), Level difference: 0 m (0 ft.)

\*4 Long period operation in a high temperature and humidity atmosphere (dew point of 23°C or more) may cause condensation to form in the indoor unit.

\*5 In case of this type of unit is connected, the maximum connected indoor unit capacity to one outdoor unit have to be less than or equal to 100%.

\*6 This unit cannot be connected to R2 or WR2-Series. (PFFY-P400, P500YM-E only)

\*7 This unit cannot be connected to PUMY-Series.

\* Details on foundation work, duct work, insulation work, electrical wiring, power source switch, and other items shall be referred to the Installation Manual.

\* Due to continuing improvement, above specifications may be subject to change without notice.

# AHU Kit Type

## PAC-AH M

Model	PAC-AH125M	PAC-AH125M	PAC-AH140M	PAC-AH250M
Air Handling Unit Size	P100	P125	P140	P200
Allowed Heat Exchanger Capacity (KW) -Heating	10.0 - 12.5	12.5 - 16.0	16.0 - 18.0	18.0 25.0
Allowed Hear Exchanger Capacity (KW) -Cooling	9.0 - 11.2	11.2 - 14.0	14.0 - 16.0	16.0 - 22.4

Model	PAC-AH250M	PAC-AH500M	PAC-AH500M
Air Handling Unit Size	P250	P400	P500
Allowed Heat Exchanger Capacity (KW) -Heating	25.0 - 31.5	40.0 - 50.0	50.0 - 63.0
Allowed Hear Exchanger Capacity (KW) -Cooling	22.4 - 28.0	36.0 - 45.0	45.0 - 56.0



# Branch Box System

## Wall mounted type



Model			MSXY-MP32VA	MSXY-MP50VA	MSXY-MP63VA	MSXZ-MP32VA	MSXZ-MP50VA	MSXZ-MP63VA
Type			Cooling Type			Heat pump		
Cooling Capacity	KW		3.60	5.20	6.60	3.60	5.20	6.60
Heating Capacity	KW					4.00	6.30	8.00
Refrigerant			R410					
Power supply	Source		230V, 50Hz					
Sound Pressure Level	Indoor unit (Quiet -Lo-Med-Hi-SHi)	dB(A)	26-29-35-40-46	29-37-41-45-49	30-37-41-45-51	26-29-35-40-46	29-37-41-45-49	30-37-41-45-49
Air Volume	Indoor unit (Quiet -Lo-Med-Hi-SHi)	CFM	162-208-272-342-434	226-300-417-491-568	307-378-448-519-734	162-208-272-342-434	226-300-417-491-568	325-392-459-526-614
Operating Current	Max	A	0.3	0.4	0.5	0.3	0.4	0.4
External finish			PS (1.0Y 9.2/0.2)					
Indoor unit	Dimension H x W x D	mm	290x799x232	305x923x250	325x1,100x238	290x799x232	305x923x250	325x1,100x238
	Weight	kg	10	13	15	10	13	15.5
Ext.Piping	Diameter Liquid	mm (inches)	6.35(1/4)	6.35(1/4)	9.52(3/8)	6.35(1/4)	6.35(1/4)	9.52(3/8)
	Diameter Gas	mm (inches)	9.52(3/8)	15.88(5/8)	15.88(5/8)	9.52(3/8)	15.88(5/8)	15.88(5/8)
Pre filter			Nano-platinum Filter					
Air cleaning filter			Electrostatic Anti-allergy Enzyme Filter (Option)					
Timer			Weekly timer					
Vertical Swing					✓			✓
Wide and Long					✓			✓



## Wall mounted type

Model			MSXZ-FP22VA	MSXZ-FP32VA
Type			Heat pump	
Cooling Capacity	KW		2.50	3.50
Heating Capacity	KW		2.90	4.00
Refrigerant			R410	
Power supply	Source		230V, 50Hz	
Special Pressure Level	Quiet-Lo-Med-Hi-SHi	dB(A)	20-23-29-36-42	
Air Volume	Quiet-Lo-Med-Hi-SHi	CFM	138-166-219-304-409	
Operating Current	Max	A	0.4	
External finish (Munsell No.)			PS (1.0Y 9.2/0.2)	
Dimensions (H x W x D)	mm		305x925x234	
Weight	kg		13.5	
Pre filter			ANTI-MOLD FILTER	
Air cleaning filter			ELECTROSTATIC ANTI-ALLERGY ENZYME FILTER (Option) DEODORIZING FILTER (Option)	
Timer			Weekly timer	
Vertical Swing			✓	
Wide and Long				

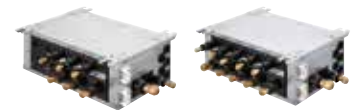

## Branch Box units

Model			PAC-MK54BC	PAC-MK34BC	
Connectable number of indoor units			Maximum 5	Maximum 3	
Power supply (from outdoor unit)			Single phase, 220/230/240 V, 50 Hz, Single phase, 220 V, 60 Hz		
Input	kW		0.003		
Running current	A		0.05 (Max. 6)		
Dimension W x D x H	mm		450x280x170		
Weight	kg		7.4	6.7	
piping connection (Flare)	Branch (indoor side)*	Liquid	mm	$\phi$ 6.35 x 5 {A,B,C,D,E}	$\phi$ 6.35 x 3 {A,B,C}
		Gas	mm	$\phi$ 9.52 x 4 {A,B,C,D}, $\phi$ 12.7 x 1{E}	$\phi$ 9.52 x 3 {A,B,C}
	Main (outdoor side)	Liquid	mm	$\phi$ 9.52	
		Gas	mm	$\phi$ 15.88	

### Notes:

- \* The piping connection size differs according to the type and capacity of indoor units. Match the piping connection size for indoor and branch box. If the piping connection size of branch box does not match the piping connection size of indoor units, use optional different-diameter joints to the branch box side. (Connect joint directly to the branch box side.)

# Remote Controller

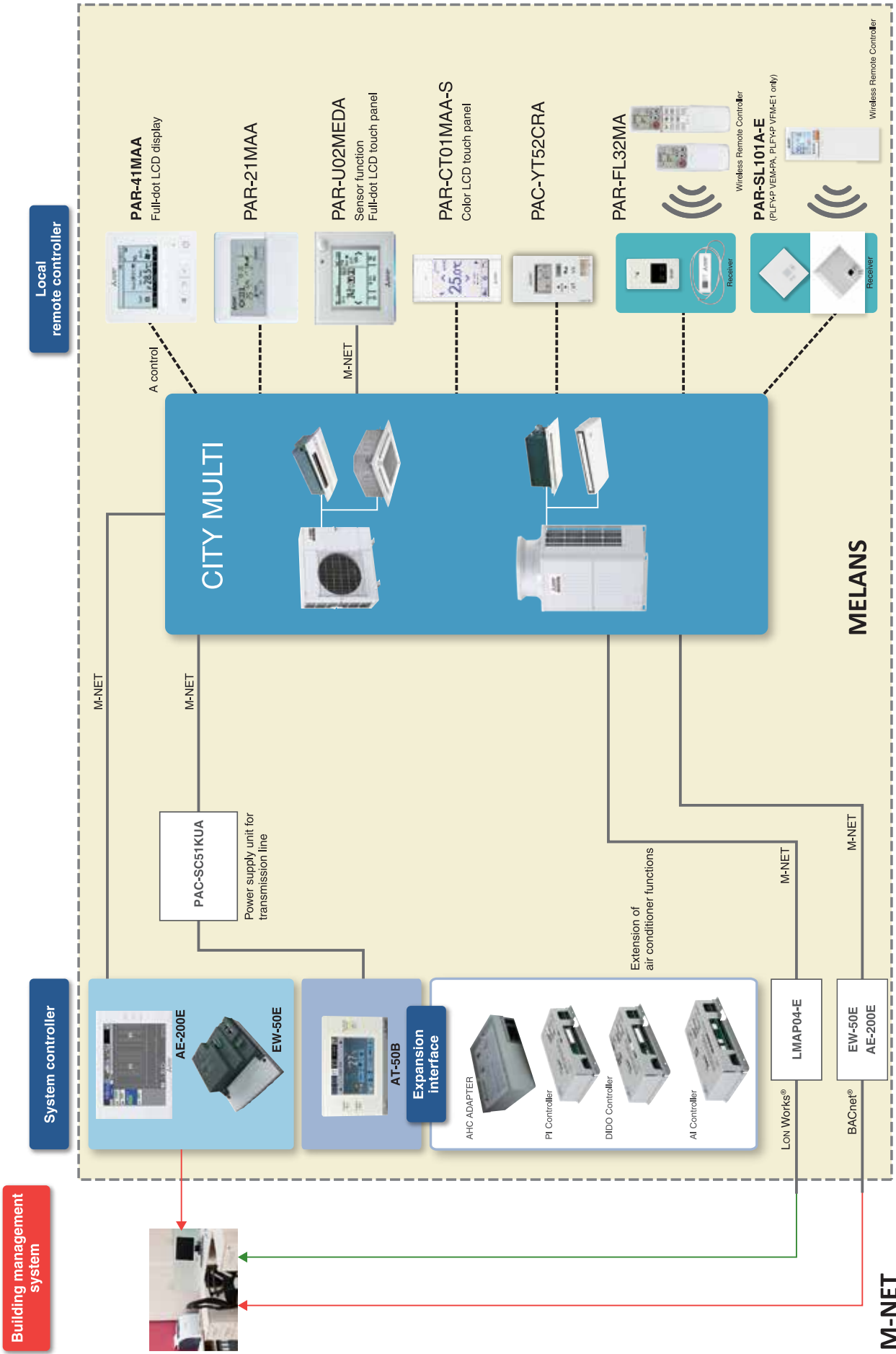

Using our MELANS products enhances air-conditioning EFFICIENCY and QUALITY, contributing to ENERGY SAVINGS and reducing running cost. We offer a wide variety of MELANS products to meet requirements - from the smallest and simplest, to the largest and most complex. We have individual remote controllers, various centralized controllers, BMS interface, etc.



# ENERGY RECOVERY VENTILATION FOR ENHANCED AIR QUALITY – LOSSNAY

City Multi VRF System is combined with Lossnay System for enhanced indoor air quality. Unified Control System allows greater design freedom.



## LOSSNAY TECHNOLOGY

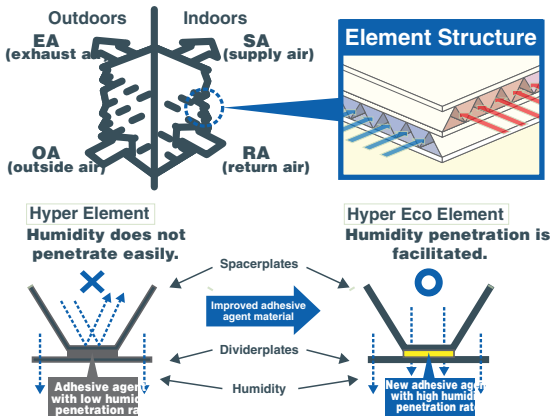
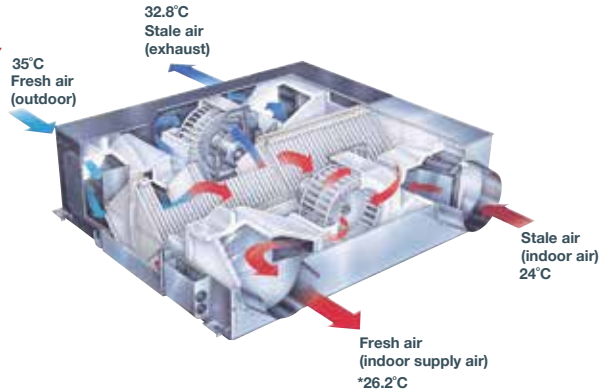
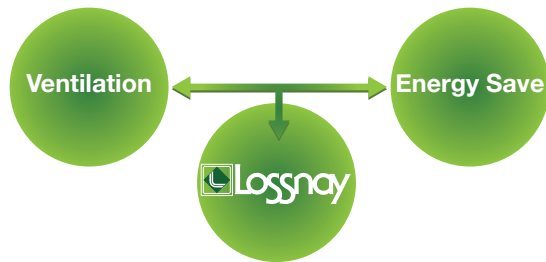

NOTE: \*LGH-100 RX<sub>5</sub>-E

## HYPER ECO CORE

Mitsubishi's developed Hyper Eco Element is on board, offering the industry's best total heat exchange efficiency. Energy conservation performance has been improved not only by reducing the air conditioning load associated with ventilation, but also by facilitating humidity penetration.

## What can be improved by introducing Lossnay?

- Ventilation with maximised comfort

### In summer

Air similar to the conditions of the cooled (dehumidified) indoor air is supplied.

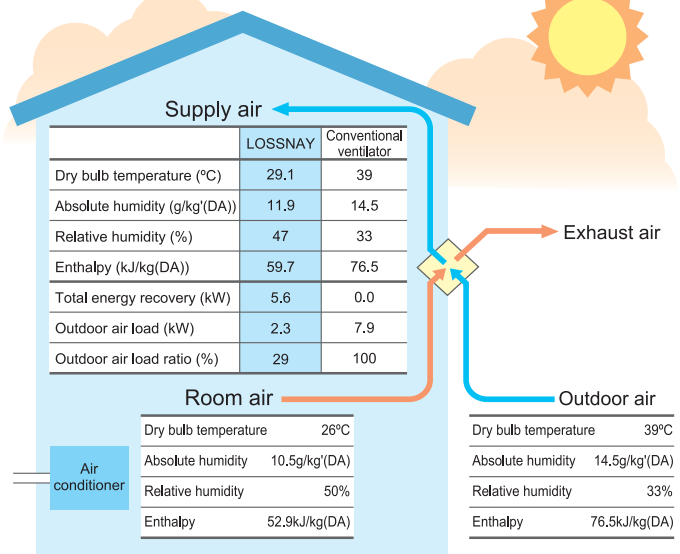

### Heat recovery calculation

$$\text{Indoor supply-air temperature (°C)} = \text{Outdoor temperature (°C)} - \left\{ \text{Outdoor temperature (°C)} - \text{Indoor temperature (°C)} \right\} \times \text{Temp recovery efficiency (\%)}$$

Calculation example : 29.1°C = 39°C - (39°C - 26°C) × 76.5%

\*The above applies to the case of LGH-100RX5 (fan speed 4).

## Filter Lineup

Optional filter	
Filter	Advanced High-efficiency filter
Model	<b>PZ-RFP<sub>2</sub> Series</b>
	
ISO 16890	ePM <sub>1</sub> 75%, ePM <sub>2.5</sub> 80%, ePM <sub>10</sub> 95%

## PZ-RFP<sub>2</sub>-E Series

### Filtration Specifications

Standard	Level	Certification body
ASHRAE 52.2-2017	MERV16	Blue Heaven Technologies
ISO16890-2016	ePM <sub>1</sub> 75%, ePM <sub>2.5</sub> 80%, ePM <sub>10</sub> 95%	Blue Heaven Technologies
GB/T 14295-2008	YG class, 99.7% (Collecting efficiency for particles that are 0.5µm or larger at rated airflow)	National Center of Quality Supervision and Inspection and Testing for Air Conditioning Equipment

\*Filtration specifications are result of tests conducted by third -party and are not guaranteed values.

## MITSUBISHI ELECTRIC MULTIPLE SPLIT TYPE AIR CONDITIONERS **R410A** Series



FM33568 / ISO 9001;2008

The Air Conditioning & Refrigeration Systems Works acquired ISO 9001 certification under Series 9000 of the International Organization for Standardization (ISO) based on a review of Quality management for the production of refrigeration and air conditioning equipment.

#### ISO Authorization System

The ISO 9000 series is a plant authorization system relating to quality management as stipulated by the ISO. ISO 9001 certifies quality management based on the "design, development, production, installation and auxiliary services" for products built at an authorized plant.



The Air Conditioning & Refrigeration Systems Works acquired environmental management system standard ISO 14001 certification.

The ISO 14000 series is a set of standards applying to environmental protection set by the International Organization for Standardization (ISO). Registered on March 10, 1998.

#### ⚠ Warning

- Do not use refrigerant other than the type indicated in the manuals provided with the unit and on the nameplate.
  - Doing so may cause the unit or pipes to burst, or result in explosion or fire during use, repair, or at the time of disposal of the unit.
  - It may also be in violation of applicable laws.
  - MITSUBISHI ELECTRIC CORPORATION cannot be held responsible for malfunctions or accidents resulting from the use of the wrong type of refrigerant.
- Our air conditioning equipment and heat pumps contain a fluorinated greenhouse gas, R410A.



# CONTROL YOUR COMFORT YOUR OWN WAY

## WHAT MAKES US THE BEST

Japanese Technology | Energy Efficient | Reliability  
Low Noise | Compatible to Outdoor Temperature up to 52°C  
Self-developed Compressor | Inverter Driven Technology



# MITSUBISHI ELECTRIC INDIA PVT. LTD.

Head Office: 3rd Floor, Tower A, Global Gateway, MG Road, Gurgaon - 122002 (Haryana)

Tel. No. (Main): 0124-6739300 | Fax: 0124-4630399 | Website: [in.mitsubishielectric.com](http://in.mitsubishielectric.com) | Email: [customersupport@asia.meap.com](mailto:customersupport@asia.meap.com)

**Customer Care Toll Free No.: 1800 102 2626**

## **NORTH ZONE**

### **Chandigarh**

Tel. No.: +91-172-460164588

Mobile No.: +91-9779740016

### **Delhi - NCR**

Tel. No.: +91-11-66057900

Mobile No.: +91-9999103302

### **Ghaziabad:**

Tel. No.: 0120-4093681

Mobile No.: +91-9319986322

### **Jaipur**

Tel. No.: +91 141-4011109

Mobile No.: +91-9950083217

### **Lucknow**

Tel. No.: +91-522-4002607

Mobile No.: +91-9540220666

## **EAST ZONE**

### **Kolkata**

Tel. No.: +91-033-40858800

Mobile No.: +91-9073949592

## **WEST ZONE**

### **Ahmedabad**

Tel. No.: +91-79-67777888

Mobile No.: +91-9319591911

### **Indore**

Tel. No.: +91-731-4098991

Mobile No.: +91-9770144696

### **Mumbai**

Tel. No.: +91-22-66116200,

Mobile No.: +91-9322164448

### **Pune**

Tel. No.: +91-20-27102000

Mobile No.: +91-7354113399

### **Surat**

Tel. No.: +91-261-4003111

Mobile No.: +91-8460067404

## **SOUTH ZONE**

### **Bengaluru**

Tel. No.: +91-80-40201600

Mobile No.: +91-8448398009

### **Chennai**

Tel. No.: +91-44-49232222

Mobile No.: +91-9205599020

### **Hyderabad**

Board No.: +91-40 43438888

Mobile No.: +91-9848974897

### **Kochi**

Tel. No.: +91-0484-4862093

Mobile No.: +91-8448397964

### **Vijaywada**

Tel. No.: +91-0866-6516999

Mobile No.: +91-9205987310

## **SALES OFFICE**

### **Bhubaneshwar**

Mobile No.: +91-9073949593

### **Coimbatore**

Tel. No.: +91-422-4385606

Mobile No.: +91-9500998901

### **Ludhiana**

Tel. No.: +91-161-4061654

Mobile No.: +91-9888548211

### **Nagpur**

Tel. No.: +91-712-2284020

Mobile No.: +91-8109847128

### **Patna**

Mobile No.: +91-9033425436

## **TECHNICAL CENTRE**

### **Ahmedabad**

Tel. No.: +91-079-67777874

### **Delhi**

Tel. No.: +91-011-66057900

### **Bengaluru**

Tel. No.: +91-080-40201600

### **Mumbai**

Tel. No.: +91-022-66116200

### **Chennai**

Tel. No.: +91-044-49232222

# MITSUBISHI ELECTRIC INDIA

[in.MitsubishiElectric.com](http://in.MitsubishiElectric.com)